

R E P O R T R E S U M E S

ED 018 399

SE 004 546

LABORATORY EXERCISES IN OCEANOGRAPHY FOR HIGH SCHOOLS.

FLORIDA ST. UNIV., TALLAHASSEE

NATIONAL SCIENCE FOUNDATION, WASHINGTON, D.C.

REPORT NUMBER GW-1752

PUB DATE

67

EDRS PRICE MF-\$0.50 HC-\$3.68 90P.

DESCRIPTORS- *INSTRUCTIONAL MATERIALS, *OCEANOLOGY, *SECONDARY SCHOOL SCIENCE, *SCIENCE ACTIVITIES, BIOLOGY, EARTH SCIENCE, LABORATORY TECHNIQUES, RESOURCE MATERIALS, SCIENCE EQUIPMENT, NATIONAL SCIENCE FOUNDATION,

DESCRIBED ARE LABORATORY EXERCISES IN OCEANOGRAPHY DEVELOPED FOR USE IN HIGH SCHOOLS BY THE SECONDARY SCHOOL TEACHERS IN THE 1967 NATIONAL SCIENCE FOUNDATION (NSF) SUMMER INSTITUTE IN OCEANOGRAPHY AT FLORIDA STATE UNIVERSITY. INCLUDED ARE SUCH ACTIVITIES AS (1) THE MEASUREMENT OF TEMPERATURE, WATER VAPOR, PRESSURE, SALINITY, DENSITY, AND OTHERS, (2) THE CONSTRUCTION AND USE OF EQUIPMENT FOR MAKING VARIOUS DETERMINATIONS, AND (3) LABORATORY DEMONSTRATIONS INVOLVING SUCH PHENOMENA AS LAND AND SEA BREEZES, GENERAL WIND CIRCULATION, SURFACE WAVES, INTERNAL WAVES AND OTHERS. EACH EXERCISE INCLUDES (1) A BRIEF DISCUSSION OF THE PHENOMENON BEING STUDIED, (2) A LISTING OF THE EQUIPMENT NEEDED AND THE PROCEDURES TO BE FOLLOWED, AND (3) COMMENTS ON HOW AND WHEN THEY COULD BE MOST EFFECTIVELY USED IN SECONDARY SCHOOL INSTRUCTION. DIAGRAMS, QUESTIONS, COMPLETION EXERCISES, TABLES OF DATA, AND GRAPHS ARE USED TO DEVELOP CONCEPTS AND TO PROVIDE NEEDED INFORMATION. ALSO REPORTED ARE SUMMARIES OF PROJECTS PERFORMED BY PARTICIPANTS AND SUGGESTIONS FOR THE UTILIZATION OF SIMILAR STUDIES IN HIGH SCHOOL CLASSES. APPENDED ARE (1) A MAP SHOWING THE COLLECTING TRIP AREAS, (2) EQUIPMENT USED ON COLLECTING TRIPS, (3) A SAMPLE OF THE FORM USED FOR RECORDING FIELD NOTES, AND (4) DIAGRAMS FOR THE CONSTRUCTION OF A DIP NET AND A COLLECTING PAIL. (DS)

U.S. DEPARTMENT OF HEALTH, EDUCATION & WELFARE
OFFICE OF EDUCATION

THIS DOCUMENT HAS BEEN REPRODUCED EXACTLY AS RECEIVED FROM THE
PERSON OR ORGANIZATION ORIGINATING IT. POINTS OF VIEW OR OPINIONS
STATED DO NOT NECESSARILY REPRESENT OFFICIAL OFFICE OF EDUCATION
POSITION OR POLICY.

THE OCEANOGRAPHIC INSTITUTE

FLORIDA STATE UNIVERSITY

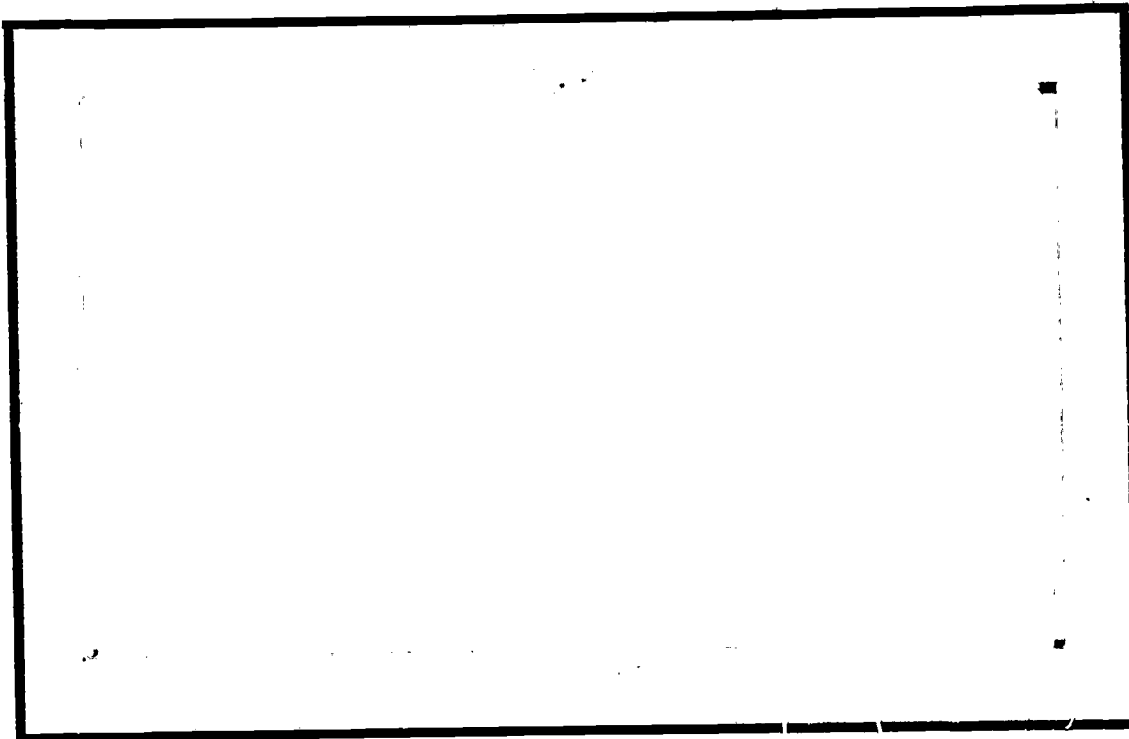

TALLAHASSEE

ED018399

SE004 346

LABORATORY EXERCISES

In

OCEANOGRAPHY

For High Schools

Developed from the
NATIONAL SCIENCE FOUNDATION
Grant GW-1752
Summer Institute in Oceanography

Florida State University
Tallahassee, Florida
June-July, 1967

CONTENTS

	Page
Oceanography and Meteorology Laboratories	
Measurement of Temperature	3
Time-Lag Coefficients for Thermometers	9
The Bimetallic Strip Thermometer	14
Effects of Radiation on the Temperatures Over the Land and Sea	16
The Land and Sea Breeze Demonstration	20
Water Vapor in the Air	23
The Measurement of Water Vapor	28
Pressure and Its Measurement	31
General Circulation--Winds	36
Surface Weather Codes	43
Scalar Field Analysis	50
Determination of Salinity	52
The Density of Sea Water	55
Temperature-Salinity Correlations	59
Surface Waves	63
Internal Waves	72
Marine Biology Laboratories	76

Measurement of Temperature

Temperature can be measured in many different ways. Among them is measuring the expansion of a material or the change in electrical resistance caused by a change in temperature. Indirect methods must be used because temperature is a relative phenomenon.

A. Measurement of Temperature by the Expansion of a Fluid.

The change in volume for a given change in temperature can be written:

$$\frac{\Delta V}{V} = B\Delta T$$

where: B = coefficient of thermal expansion
 ΔV = change in volume
 V = original volume
 ΔT = change in temperature

The value of B depends on the material and the units of temperature used.

For the following diagram:

At temperature = T_0 the fluid is at mark A.

At this temperature the volume of the fluid is V_0 .

The diameter of the tubing is $2r$.

At temperature = T the fluid has expanded, filling the tube up to C which is the distance h above mark A.

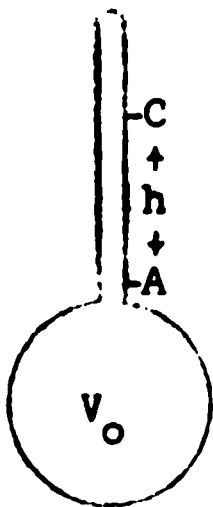

We can write:

$$\Delta T = T - T_0 = \frac{\Delta V}{V \cdot B} \quad \text{where } V = V_0; \Delta V = \pi r^2 h;$$

and T is in degrees Kelvin.

Typical coefficient of expansion in cgs units are:

Mercury B = 0.00018
 Alcohol (Ethyl) B = 0.00112
 Gases B = 0.0037

As a sample calculation consider the following example for a mercury thermometer. Assume:

$$r = 0.01 \text{ cm}; \quad V_0 = 2 \text{ cm}^3; \quad T_0 = 273^\circ; \quad h = 5 \text{ cm}$$

$$\Delta T = \frac{\Delta V}{V \cdot B} \frac{\pi r^2 h}{V \cdot B} = \frac{3.14 \cdot 0.0001 \cdot 5.0}{2 \cdot 1.8 \times 10^{-4}}$$

$$\Delta T = 4.36^\circ$$

$$T = T_0 + \Delta T = 277.36^\circ$$

Errors encountered in using this type of thermometer are:

1. The expansion of the material (glass) which encases the fluid causes V_0 to increase so the fluid is not as high in the $^\circ$ tube as it should be.
2. An uneven bore causes the height, h , to be a non-linear function of temperature. This implies that ΔV does not equal $\pi r^2 h$.
3. The scale might not be properly marked.

B. Construction of a Gas Thermometer.

Equipment:

- 1 250 ml flask
- 1 stopper with hole
- 1 length of glass tubing (5")
- 1 20 cm scale
- 3' clear plastic tubing
- Water

Procedure:

1. Insert glass tube into stopper.
2. Insert stopper into flask.
3. Fill plastic tubing half full with water.
4. Insert one end of plastic tubing on glass tube in the stopper holding the other end up so that water does not escape. (See diagram).
5. Attach the scale to the plastic tubing so that the water level in the tube under the flask can be measured.
6. Adjust the free end of the plastic tubing so the water levels in each arm of the tubing are at the same height. Record the water level. (This adjustment causes the pressure on the gas inside the flask to be the same as the atmospheric pressure.)

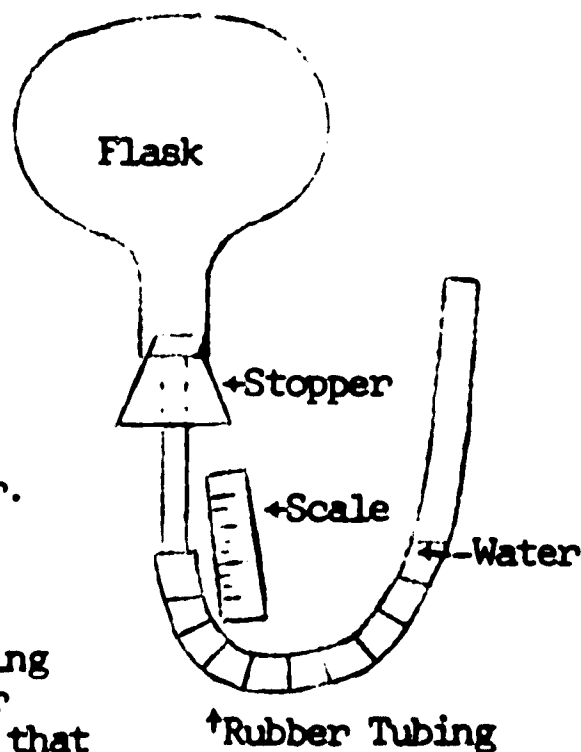

7. Change the environmental temperature of the flask (take it outside). Readjust the plastic tubing to get the pressure equal, then record the change in height of the water.
8. This change in height is proportional to the change in temperature.

Any changes in temperature will be reflected by a change in the height of the water in the tube. Calculate the change in the height of the water column for the difference in temperature between indoors and outdoors at constant pressure. Check your results with your gas thermometer.

C. Relative Calibration of Thermometers.

Because of differences in manufacturing few if any thermometers will give the same reading when they are at the same temperature. There are many situations when it is desirable to measure temperatures when the same thermometer cannot be used continuously. In these situations it is necessary to be able to relate the reading of one or several thermometers to the readings of another. The thermometer to which the others are related is called a standard thermometer. The most reliable standard thermometer is held by the U.S. Bureau of Standards in Washington, D. C. However, since it is not available for our immediate use we will create a standard of our own, any thermometer which we choose, which at some later time we can relate to the standard in Washington if we choose.

We will now proceed to calibrate several thermometers relative to our standard so that readings on any one of them can be compared to any other which we have calibrated.

Equipment:

Large thermos bottle or insulated container
Ice
Hot water
Thermometers to be calibrated (household)
Standard thermometer (any thermometer we desire)
Graph paper

Procedure:

- a. 1. Insert the thermometers along with the standard in the thermos which has been filled with ice water.
2. While stirring the water, record the temperatures of all the thermometers in the chart form shown below.

3. Add some hot water to the thermos to raise its temperature.
4. Repeat steps 2 and 3 as often as desired.

Data format:

	Standard	Thermometer 1	Thermometer 2, etc.
T e m p e r a t u r e	41.5°C	41.8°C	41.0°C
	63.0°C	63.4°C	62.6°C
	etc.	etc.	etc.

- b. After "a" is finished, on graph paper plot the temperature read on the thermometer against the difference between this temperature and that one recorded for the standard thermometer. Connect all the points with a smooth curve (straight lines may be used). Use of this graph--(see example)--assume a thermometer A is used to take a reading at some time. Find the correction from its calibration graph and subtract this value from its reading. This will give you the temperature which would have been read if the standard had been used.

Example: Thermometer A read 74.0°F. What would the reading of the standard have been? Solution: For a reading of 74.0°F the correction on the graph is +1.4°F. Subtracting this from the reading gives 72.6°F. The standard would have read 72.6°F.

QUESTIONS:

1. Why do you suppose a thermos bottle was used for the water bath?
2. Why should you stir the water in the water bath?
3. How good is this calibration if the laboratory standard is not accurate?

ANSWERS:

1. Thermos bottles were used to inhibit caloric escape and maintain a relatively constant temperature.
2. We stirred frequently because the water has a tendency to layer by temperature.
3. If the laboratory standard is not accurate, all of our readings will be in error relatively. We could assume that this error will follow a constant pattern, and, therefore, our results should be usable to obtain relatively accurate calculations.

POSSIBLE PLACES FOR ERROR:

1. Continuous caloric escape at surface of water bath.
2. Since water has a tendency to layer in different temperature layers, we are actually reading the temperature of only one layer. This should be minimized by stirring frequently.
3. Human error in reading the thermometer.
4. The smallness of the scale of the thermometer places a definite limitation on our ability to accurately read it.

-8-
CALIBRATION CURVE FOR THERMOMETER A

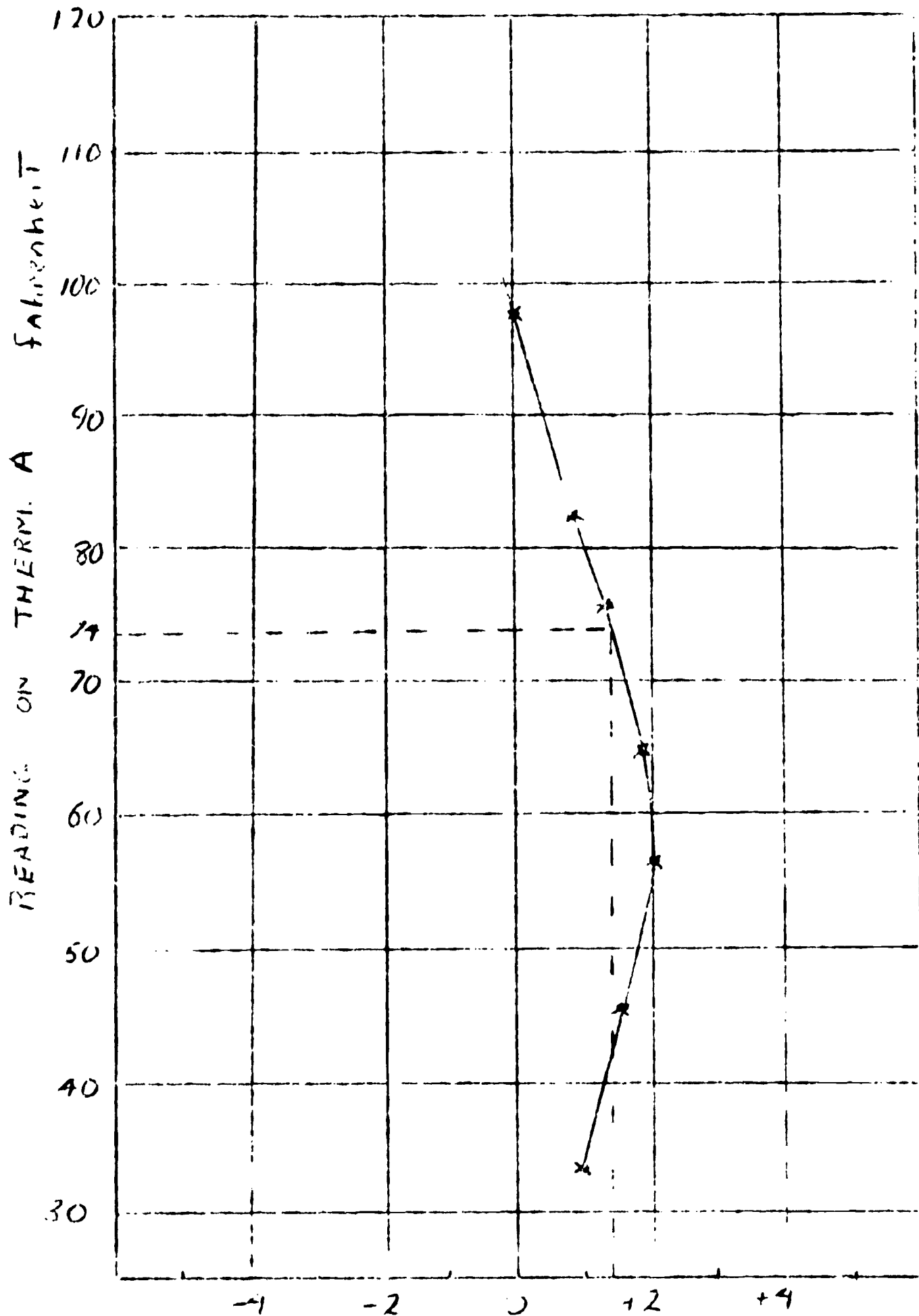

STO	A
33.0	34.0
44.5	46.0
55.0	57.0
63.2	65.0
74.7	76.0
82.1	87.0
94.0	98.0

Time-Lag Coefficients for Thermometers

One of the properties of thermometers that must be considered when designing an experiment involving temperature is the response time, i.e., just how quickly does the temperature of the thermometer adjust to the environmental temperature. Some studies require extremely short response times such as those in turbulence studies. For these, the mercury in glass thermometer is too slow, and one must use electrical resistance thermometers. On the other hand, there are studies, such as the measuring of soil temperatures, where rapid response thermometers would be quite unnecessary and, perhaps, highly impractical. Here the slow response thermometers are well suited.

Suppose we now consider how one would assign a numerical value to the response time of a thermometer. If a thermometer is placed in a medium which differs in temperature from that of the thermometer, the temperature of the thermometer will asymptotically approach the temperature of the medium. And, if the temperature of the medium is indicated by T_m and that of the thermometer by T , we can express the time rate of change of the temperature of the thermometer by

$$\frac{\Delta T}{\Delta t} = -\frac{1}{\lambda}(T - T_m)$$

where Δt refers to the change in time and $1/\lambda$ is defined as the lag coefficient. Integration of this equation yields:

$$T_0 - T_m = (T_0 - T_m)e^{-\left(\frac{1}{\lambda}\right)t}$$

where T_0 is the initial temperature of the thermometer. This expression relates the rate at which the thermometer temperature approaches that of the environment. Finally, if we take the logarithm of both sides of this equation, we have

$$\log_{10}(T - T_m) = \log_{10}(T_0 - T_m) - \left(\frac{1}{\lambda}\right) \cdot t$$

which is nothing more than an equation of a straight line for temperature plotted against time on semi-log paper. The slope is given by $1/\lambda$ and the intercept (on the log scale) is $\log T_0 - T_m$. Using this expression one is able to determine the response time of a thermometer or its lag coefficient by observing the rate at which the temperature of the thermometer approaches that of the environment.

This, then, will be the object of this experiment.

A. Measurement of a Time-Lag Coefficient.

Materials:

Extension cord and flood lamp
Household outdoor alcohol thermometer and cardboard
mount
Wrist watch with a second hand
2-cycle semi-log graph paper
Linear graph paper

Procedure:

Set up the apparatus by taking a common outdoor thermometer, removing it from its glass case, and using a piece of stiff cardboard to mount the instrument so that the bulb is exposed to the free air. Let the temperature of the thermometer come to equilibrium with the environment and record this temperature calling it T_m .

Three people should be involved in this experiment: one to read the thermometer, the second to keep track of the time, and the third to record the reading.

When the thermometer has reached equilibrium with the environment and the temperature recorded, place the flood lamp about 12 inches above the bulb and heat the thermometer until it has reached 100°F. Immediately, turn off the flood lamp and note the time. This, then, is T_o .

As the temperature of the thermometer drops, it is to be recorded every fifteen seconds. The person reading the thermometer should read the temperatures to the nearest half-degree and should attempt to minimize the parallax error in the reading. The person in charge of the timing should notify the reader five seconds before the time of the reading that the reading is coming up and the recorder should make note of any peculiarities observed. The reasons for these will become apparent as one works up the data.

After the data has been obtained, each person should carry out the remainder of the experiment by himself.

Take a piece of linear graph paper and, using suitable scales, plot up the temperature difference ($T - T_m$) on the ordinate versus the time on the abscissa. When this has been done, take a piece of two-cycle semi-log paper and, again, plot the temperature difference on the ordinate and the time on the abscissa.

Using the data appearing on the semi-log paper, attempt to draw one straight line which most accurately depicts the data (i.e., fit a straight line to the data) and extend this line so that it intersects the ordinate.

Now that you have a straight line and its intercept, you can make use of the equation:

$$\log_{10}(T - T_m) = \log_{10}(T_0 - T_m) - \left(\frac{1}{\lambda}\right) \cdot t$$

and solve for λ using your data.

Observations:

1. What is the value of your time-lag coefficient?
2. What is the shape of the curve for the data plotted on linear graph paper?
3. What can you say about the rate at which temperature of the thermometer approaches that of the environment during the initial moments versus some time later?
4. Does the temperature of the thermometer actually ever reach that of the environment?
5. Can you think of other situations where the time-lag might be an important consideration?

B. Time-lag Dependence Upon Ventilation.

The previous experiment demonstrated how one is able to determine the time-lag coefficient. In this experiment, you will find that the lag coefficient is a function of the ventilation or wind speed over the thermometer.

Materials:

Extension cord and flood lamp
Household outdoor thermometer
Time piece or watch
2-cycle semi-log paper
Wind tunnel and fan

Procedure:

This experiment calls for a wind tunnel which can easily be constructed from a cardboard carton and a small room fan.

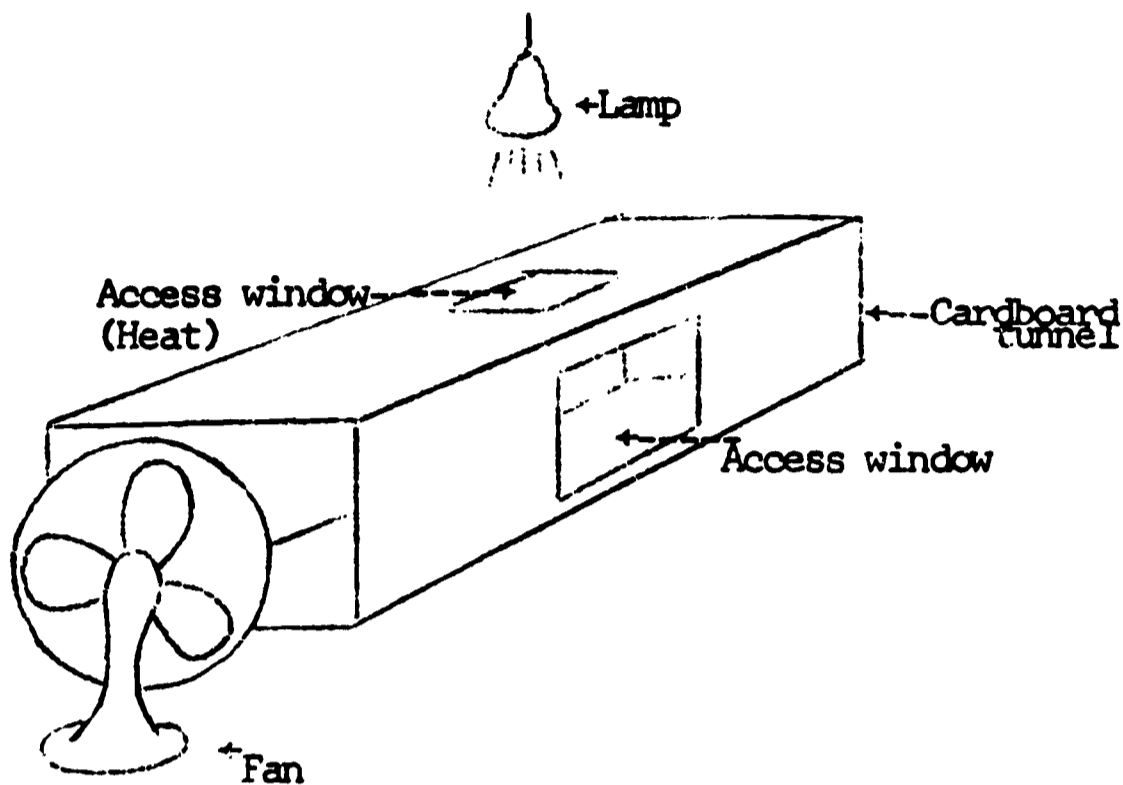

PART A: Take the thermometer, remove it from its glass case and mount it with a piece of cardboard as done in the previous experiment. Place this thermometer in the center of the wind tunnel and let it come to equilibrium with its surroundings. As soon as you are satisfied that the thermometer is in equilibrium with its surroundings, record the temperature. Now, turn on the spot light and heat the thermometer to 100°F noting how long it takes to do so in seconds. Record the time.

As soon as the thermometer has reached 100°F , turn off the spot light and read the temperatures every fifteen seconds to the nearest half-degree as the temperature falls. Continue doing so until the thermometer is nearly equal to the initial temperature. With this data, determine the lag coefficient as was done in the previous experiment.

PART B: Using the same apparatus and the same procedure, rerun the experiment with the fan blowing air directly on the thermometer bulb. Again, determine the lag coefficient.

PART C: Now, rerun the experiment with the fan drawing air over the bulb. This assumes that the fan will pull less air than it pushes and, thus, yield lower ventilation velocities. Again, compute the lag coefficient.

PART D: In this final part, the thermometer is returned to its glass shield and placed in the path of the air stream. The fan will be blowing directly on the thermometer. A time-lag coefficient is computed for this part, also.

Observations:

1. What can you immediately say about the effects of ventilation of the magnitude of the time-lag coefficient?
2. What effect does the glass shield have on time-lag?
3. Are the times it took the thermometer to rise to 100°F in the various parts consistent with the time-lag coefficients computed? Why or why not?
4. How might you establish a relationship between ventilation (or wind speed) and the time-lag coefficient?
5. In this experiment it was recommended that the same thermometer be used for all parts. Why should one do this?
6. If you were to design a liquid-in-glass thermometer, how would you design it so as to minimize the time-lag?

COMMENTS:

The general feeling was that this experiment could be used used as it is in a high school physics laboratory. Depending upon the amount of time available Parts A and B could be combined. If time is available, both pre- and post-discussions should be held to maximize the understanding.

As far as modifications are concerned, a wind tunnel is not absolutely necessary if one only desires to show the difference between ventilated and unventilated cases. On the other hand, one could purchase a small inexpensive commercial anemometer and attempt to show some relation between wind speed and the time-lag of the thermometer. Finally, it might be worth while to compare the different types of thermometers such as the bimetallic strip thermometer and the alcohol thermometer.

The Bimetallic Strip Thermometer

In addition to the already mentioned means of measuring temperature, one is able to indicate temperature changes by expansion and contraction of metals. It has been found that the change in length of a metal for a given temperature change can be related to the initial length and the temperature change itself. We can write:

$$\Delta L = \alpha L_0 \Delta t$$

where ΔL is the change in length, α is the coefficient of linear expansion, L_0 is the initial length and Δt is the temperature change.

The bimetallic strip thermometer utilizes the fact that the coefficient α differs from one metal to the next. Consider the following table:

<u>Substance</u>	<u>α per degree Celcius</u>
Aluminum	24×10^{-6}
Brass	20
Copper	14
Glass	4.9×10^{-6}
Steel	12
Invar	0.9
Quartz	0.4
Zinc	26.0

The thermometer is constructed from two thin flat strips of metal welded or riveted together as seen here:

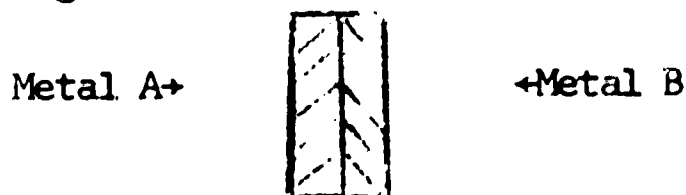

If metal A has a larger coefficient of expansion than metal B, the compound strip will bend into a curve for a change in temperature.



This bending of two strips of metal is much easier to observe than the change in length of a single metal.

Procedure:

You will be given a household bimetallic strip thermometer. For a qualitative feeling of the time-lag coefficient for this type of thermometer, use a flood lamp to heat this thermometer to 100° as was done in previous time-lag experiments.

Observations:

1. Without actually computing a lag coefficient, how would you say the response time for this type of thermometer compared with the alcohol thermometer?
2. Using the table above, which two metals appear preferable in the construction of a bimetallic strip thermometer?

Effects of Radiation on the Temperatures Over the Land and Sea

The amount of radiation received by a certain area on the surface of the earth and the thermal properties of the area are prime factors in the determination of the local climate. We shall concern ourselves here with the latter of these two--in particular, the thermal properties of land as compared to those of water--and try to determine in what manner they effect the climate of the area. As an example: it is known that continents experience far warmer summer temperatures and far colder winter temperatures than do the oceans.

These differences in seasonal temperatures are due in part to the following:

1. It takes roughly three times as much heat energy to raise the temperature 1° Centigrade for a unit volume of water as for a unit volume of sand. Hence, for a given amount of heat energy applied to the sand and to the water, the final temperature change of the sand will be three times that of the water temperature change.
2. Light energy penetrates water much further than it does soil. Because of this, water will show a more uniform temperature with depth, whereas, the soil will exhibit a marked temperature contrast with depth.
3. Water is continually mixed by the turbulent motions of the fluid while soil remains immobile. This mixing permits more uniform temperatures throughout the volume of water. Soil, on the other hand, will exhibit large differences in temperature over small distances because it is unable to mix with its surroundings.
4. This last point concerns evaporation and is not to be under-emphasized particularly over the open ocean. Evaporation from any water surface is going to be characterized by cooling because of the heat lost in evaporating water. Dry soil will not be subject to such a loss of heat.

Before progressing to the explanation of the experiments demonstrating the thermal properties of land and water, you might recall the common summertime experience of beach-goers. If you have ever spent a day at the beach along the oceans, you may have noticed how hot the surface of the sand was, while just below the surface the sand was quite cool. As you then waded into the water, you noticed that the water was generally uniform in temperature and cooler than

the sand on the beach. These temperature differences can, in general, be attributed to the above physical processes operating on water and land.

Materials:

Two plastic sandwich containers
Two simple outdoor thermometers
Two thermometer position clamps
Water
Clean sand
One cookie tin
Ring stand with clamp
Extension cord and flood lamp

Procedure:

PART A: Set up the apparatus by filling one of the sandwich containers with dry sand and the other with water. On the bottom of the sandwich container containing water, sprinkle some sand so as to reduce the amount of reflection by the cookie tin.

For the first part of this experiment, place two thermometers so that their bulbs are just below the surface of the water and the sand. Let the two thermometers come to equilibrium with the sand and the water. Record their readings.

Now, turn on the flood lamp which is centered right over the containers of sand and water and read the two thermometers every 60 seconds for the next five minutes. These temperatures should be read to the nearest 1/2-degree. At the end of the five-minute period, turn off the flood lamp and continue reading the thermometers every minute for the next six or seven minutes. Record all of these temperatures. Now, leave the apparatus for a moment in order that equilibrium conditions may be reached and try to answer the following questions:

1. Which of the two, the water or the sand, heats up the most rapidly? Which cools the most rapidly? What reasons can you give for this?
2. Keeping in mind these results, can you say anything about the temperatures you might find over deserts during a twenty-four-hour period? Can you say anything about the temperatures in the water and of the air just above the water at sea for a 24-hour period?

PART B: Returning to the apparatus, place the thermometer bulbs at the bottom of the containers of sand and water. Again, let the thermometers come to equilibrium and, then, read them for your initial temperature. Repeat Part A by turning on the flood lamp and reading the thermometers every minute for the next five minutes and, also, while letting them cool. Following this, attempt to answer the questions:

1. Again for this section, which of the two, the sand or the water, heats up more rapidly? Which cools more rapidly?
2. How does the rate of rise of the temperature in the water and in the sand compare with the rate of rise in temperature of Part A above? Why do you think this is so?
3. How does the rate of cooling of the soil and of the water compare with that of Part A? How do you explain this result?
4. If we were to place the thermometers much deeper in the soil and in the water, what would you expect in light of the above results?
5. What effect would stirring the water have on the temperature of the water while heating?
6. Why do you suppose the temperature in the soil continued to rise for a short time after the source of light had been shut off?

PART C: For the final part of this experiment, place the thermometers just below the surface of the water and sand as in Part A. Sprinkle the sand covering the thermometer bulb lightly with water and repeat Part A.

1. How does the rate of change in temperature of the soil for Part C compare with Part A.
2. What can you then say about moist soil versus dry soil?

COMMENTS:

The experiment "Effects of Radiation on the Temperature Over the Land and Sea" can also be presented in a high school science laboratory with little if any modification. It was suggested that

perhaps the results would be more conclusive if deeper containers were used and the results plotted on linear graph paper. If the experiment were done in conjunction with the land and sea breeze demonstration, a student would immediately realize the significance of such an experiment.

The Land and Sea Breeze Demonstration

A common phenomenon experienced by those people living only a few miles from a coastal area is the so-called land and sea breeze. This phenomenon is manifested during the day by air flowing from the sea toward the land, offering some relief from the heat of the day, and at night blowing from the land toward the sea.

The classical explanation for the sea breeze and land breeze is as follows. During the day the land is heated up by the rays from the sun more than the oceans. (Recall the experiment "Effects of Radiation on Land and Sea".) The heating of the air immediately over the land causes it to expand and become less dense. This less dense air will rise and will be replaced by the cooler and more dense air found over the ocean. At the same time the air over the oceans that replaces the rising air over land, is itself replaced by air above it which, in turn, is replaced by the rising air over the land. Thus, we have a continuous circulation driven by the sun with rising air over the land, moving toward the sea aloft, descending over the water and moving toward the land during the day. This is the sea breeze.

The land breeze occurs during the evening hours when the sun is no longer heating the earth's surface. The land is actually cooling while the sea remains warm. Eventually, the point is reached where the ocean is warmer than the cooling land and air begins to rise over the water and descend over the land. A circulation is set up which is the reverse of that of the sea breeze.

This phenomenon can be demonstrated quite easily in the laboratory. One needs a box with a glass or clear plastic window and top. This can be constructed from a cardboard box or scrap lumber. An aquarium with a glass top is ideally suited.

To represent the land and sea, the floor of the left half of the box should be covered with water in a container and the other half with some substance such as charcoal representing soil. Now, if one heats this enclosed land and sea system from above with a spotlight which simulates the role of the sun, then rising motion will occur over the land and subsiding motion over the water. In order to trace these currents, a few drops of ammonium hydroxide placed in a bottle cap beside a few drops of hydrochloric acid in another cap, will produce a smoke trail sufficiently visible to follow the air motions. A black background made from construction paper will aid in following the smoke trail.

Materials:

- Aquarium or wooden box with transparent front and top
- Dark soil (charcoal)
- Water

Materials: (continued)

Hydrochloric acid
Ammonium hydroxide
Flood lamp
Ring stand

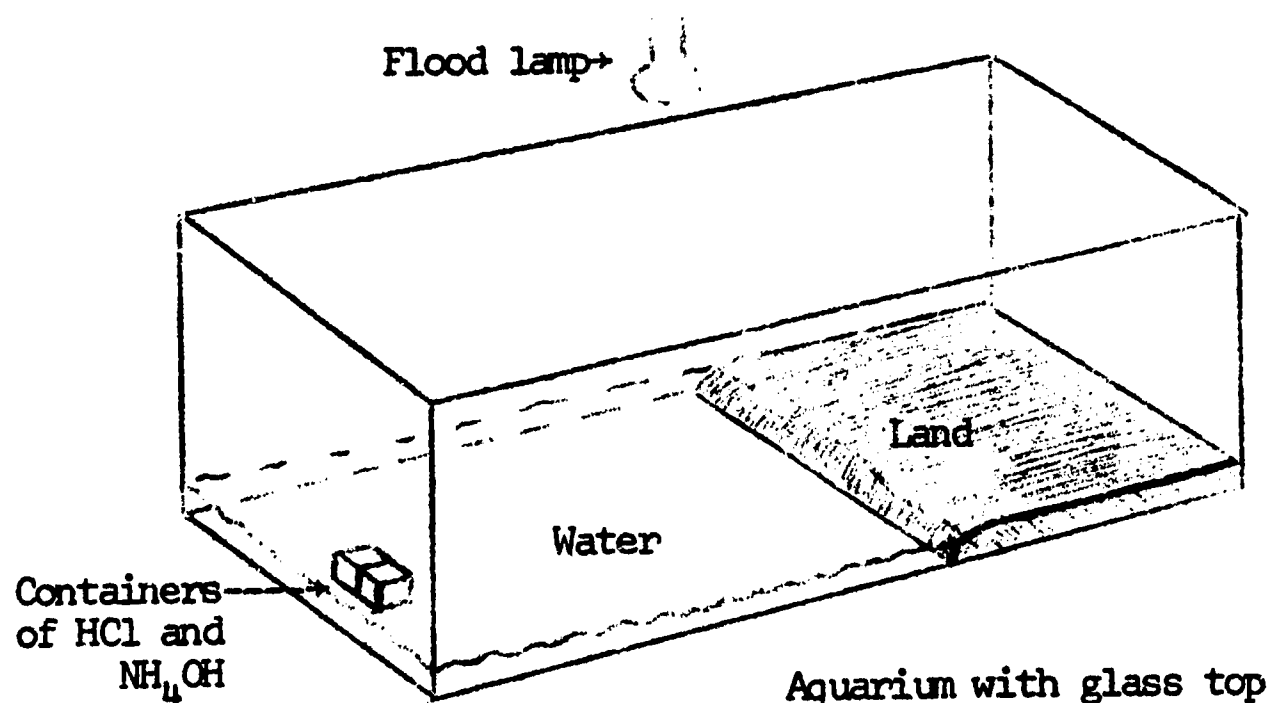

Procedure:

1. Set up the apparatus as it appears in the above diagram. Place about one inch of water in the aquarium.
2. Carefully fill two small containers at one end of the tank: one with hydrochloric acid and the other with ammonium hydroxide. Care should be used with these reagents.
3. Replace the cover on the aquarium and turn on the spot light centered over the water and land.
4. Observe the circulation that is set up.
5. When the aquarium is filled with smoke, remove the glass top and permit the smoke to escape.
6. Now place the island in the center of the aquarium with water on both sides. Repeat the experiment.

Questions:

1. Sketch the circulation patterns of the land and sea breeze.
2. Sketch the circulation pattern for the sea breeze you observed when the land was placed in the center of the tank.
3. Where might a circulation pattern of this type be set up?
4. What are the forces responsible for the sea breeze?
5. Suppose the sea breeze were not observed at a coastal city on a particular day during the summer. What phenomenon might have prevented a sea breeze from forming.

COMMENTS:

For maximum benefit, this experiment should be a part of the experiment "Effects of Radiation on Land and Sea" or should immediately follow it. If time would not permit this, it could be used as a class demonstration followed by a discussion.

Instead of using open bottle caps floating in the water for the HCl and NH₄OH, two bottles could be connected to a "Y" joint with pinchcocks below the joint so that the flow of tracer smoke could be controlled. The outlet tube could be inserted through a hole cut into the side of a cardboard box or lowered into an aquarium from the top. ~~Since glass is expensive, a cardboard cover could be used for the aquarium.~~ This would also eliminate the problem of leaks around the hose going into the aquarium.

~~If desired, a cardboard outlet representing clouds could be used to shield the land from the lamp. Hopefully, this would allow the water to be heated but not the land, and no sea breeze would be formed.~~) OK

During the summer, it might be possible to move the laboratory outdoors, thereby eliminating the need for lamps. This would also serve as reinforcement for the fact that it is the radiant energy of the sun that is the driving force for the system.

Water Vapor in the Air

We know that air is chiefly a mechanical mixture of two gases: nitrogen and oxygen. In addition to these, there are several other gases which make up a very small portion of our atmosphere. The most important of these is water vapor which can be present in amounts ranging from one to four per cent. The importance of this gas goes almost without saying because water itself can exist in three different states at normal meteorological temperatures: a gas, a liquid, or a solid. Thus, it is responsible for rain, clouds, snow, etc.

The amount of water vapor in the air can be expressed as vapor pressure, dew point, relative humidity, absolute humidity, specific humidity, and wet-bulb temperature to name just a few. For the moment we shall be concerned with only the vapor pressure.

Each of the gases in the atmosphere separately exerts a pressure called its partial pressure. Thus, we can use the water vapor pressure as a measure of the amount of water in the air. The maximum amount of water vapor that a volume of air can hold is called the saturation vapor pressure and is determined solely by temperature. The higher the temperature, the higher the saturation vapor pressure will be and, hence, the air can hold a larger amount of water vapor. In the Arctic regions where temperatures are very low, vapor pressures may be as low as 0.02 millibars; whereas, in the tropics where the temperatures are high, the vapor pressure may be as high as 50 millibars. The fact of the matter is that only slight changes of temperature can produce large changes in the air's ability to hold water.

Suppose we define E as the maximum amount of water vapor pressure or the saturation vapor pressure of a volume of air for a given temperature; suppose that e is the actual vapor pressure. The ratio e/E multiplied by 100 is defined as the relative humidity in per cent. We can write:

$$\text{Relative humidity} \equiv RH \equiv 100 \frac{e}{E}$$

Now, if we take a volume of air whose temperature is 60°F and which is saturated (i.e., it has a relative humidity of 100%) and warm this air 20° to 80°F while neither adding nor subtracting water vapor, the relative humidity at 80°F will be 50%. This means that the air's capacity to hold water has doubled for a twenty-degree increase in temperature.

One of the more common devices used to measure the amount of water vapor in the air is a psychrometer. This consists of dry- and wet-bulb thermometers mounted side-by-side on a common support. Both thermometers are mercury in glass thermometers of identical construction. The

wet-bulb thermometer is mounted slightly lower on the support and has a close fitting cloth wick around its bulb. The wet bulb is wetted with pure water, and the psychrometer is ventilated to obtain wet- and dry-bulb temperatures. The dry-bulb temperature is simply the temperature of the air and the wet-bulb temperature is the lowest temperature obtained by evaporating water from the cloth wick of the wet bulb. Using these two temperatures one is able to determine all of the water vapor parameters.

Exercise A: Using the tables provided answer the following questions.

1. What is the relative humidity when the dry-bulb temperature is 60°F and the wet-bulb temperature is 54°F ? _____
2. When the dry-bulb temperature is 71°F and the wet-bulb temperature is 69.1°F , what is the dew-point temperature? _____
(The dew-point temperature is the temperature to which a volume of air containing water vapor must be cooled at constant pressure in order to produce saturation.)
3. What is the vapor pressure of air saturated at 20°F ? _____
4. What is the vapor pressure of air saturated at 40°F ? _____
5. What is the vapor pressure of air saturated at 60°F ? _____
6. What is the vapor pressure of air saturated at 80°F ? _____
7. Considering your answers to #4 and #5, if the relative humidity of air is 100% at a temperature of 40°F , give the approximate relative humidity of the same air at the same pressure if its temperature were increased to 60°F . _____
8. Considering your answers to #3-7, what general statement can you make concerning the effect on relative humidity when air temperature is increased 20°F ? _____

9. What is the wet-bulb temperature when the air temperature is 75°F and the dew point is 69°F ? _____

10. What is the relative humidity when the air temperature is 65°F and the dew-point temperature is 61°F?
- _____

Exercise B: Complete this table.

	Temperature		Difference	Relative Humidity	Dew Point	Vapor Pressure
	Dry bulb	Wet bulb				
#1	60.0	57.5				
#2			3.0	75		
#3	50.0				44	
#4	49.0					.298
#5		39.0	5.0			
#6	63.5	63.5				
#7	70.2	65.2				
#8	52.1	48.0				

Exercise C: General Questions on Water Vapor in the Air.

1. If the temperature of a parcel of air is increased, pressure remaining constant, will the capacity of the air for water vapor increase or decrease? _____
2. Is the value of the wet-bulb temperature usually numerically the same as the dew point? _____
3. Is the wet-bulb temperature ever the same as the dry-bulb temperature? _____
4. Is the wet-bulb temperature usually equal numerically to the relative humidity? _____
5. Upon what does the capacity of air for water vapor depend?

TABLE VI.—DEW POINT IN DEGREES FAHRENHEIT

[Pressure = 29.0 in.]

Air Temperature	Vapor Pressure	Difference between Dry- and Wet bulb Temperature															
		0.5	1.0	1.5	2.0	2.5	3.0	3.5	4.0	4.5	5.0	5.5	6.0	6.5	7.0	7.5	8.0
20	0.103	18	17	15	13	11	8	5	2	-1	-5	11	18	-30			
21	0.108	19	18	16	14	12	10	7	4	1	-3	8	14	-23	-42		
22	0.113	20	19	17	15	13	11	9	6	3	-1	5	10	-17	-29		
23	0.118	22	20	18	16	14	12	10	8	5	1	3	7	-11	-22	-10	
24	0.124	23	21	19	18	16	14	11	9	6	3	0	4	-10	-17	-28	
25	0.130	24	22	21	19	17	15	13	11	8	5	2	-6	-12	-21	26	
26	0.136	25	23	22	20	18	16	14	12	10	7	4	-4	-9	-15	26	
27	0.143	26	24	23	21	20	18	16	14	12	9	6	1	-5	-11	19	
28	0.150	27	25	24	22	21	19	17	15	13	11	8	5	-2	-7	11	
29	0.157	28	26	25	24	22	20	19	17	15	12	10	7	4	-1	9	
30	0.164	29	27	26	25	23	22	20	19	16	14	12	9	6	-3	-1	-5
31	0.172	30	29	27	26	24	23	21	20	18	16	13	11	8	5	2	1
32	0.180	31	30	28	27	25	24	22	21	19	17	15	13	10	8	4	1
33	0.187	32	31	29	28	26	25	23	22	20	19	17	15	12	10	7	3
34	0.195	33	32	30	29	27	26	24	23	21	20	18	16	14	12	9	6
35	0.203	34	33	31	30	28	27	25	24	22	21	20	18	16	14	11	8
36	0.211	35	34	32	31	29	28	26	25	23	22	21	20	18	15	13	11
37	0.219	36	35	33	32	30	29	27	26	24	23	22	21	19	17	15	13
38	0.228	37	36	34	33	31	30	28	27	25	24	23	22	21	19	17	14
39	0.237	38	37	35	34	32	31	29	28	26	25	24	23	22	21	19	16
40	0.247	39	38	37	35	34	33	32	31	29	28	27	25	24	22	20	18
41	0.256	40	39	38	37	35	34	33	32	30	29	28	26	25	23	21	20
42	0.266	41	40	39	38	36	35	34	33	31	30	29	28	26	25	23	21
43	0.277	42	41	40	39	37	36	35	34	32	31	30	29	27	26	24	22
44	0.287	43	42	41	40	38	37	36	35	33	32	31	30	29	27	26	24
45	0.298	44	43	42	41	40	39	37	36	35	34	32	31	30	29	27	26
46	0.310	45	44	43	42	41	40	39	37	36	35	34	32	31	30	28	27
47	0.322	46	45	44	43	42	41	40	39	37	36	35	34	32	31	30	28
48	0.334	47	46	45	44	43	42	41	40	39	37	36	35	34	32	31	30
49	0.347	48	47	46	45	44	43	42	41	40	39	37	36	35	34	32	31
50	0.360	49	48	47	46	45	44	43	42	41	40	39	37	36	35	34	32
51	0.373	50	49	48	47	46	45	44	43	42	41	40	39	37	36	35	34
52	0.387	51	50	49	48	47	46	45	44	43	42	41	40	39	37	36	35
53	0.402	52	51	50	49	48	47	46	45	44	43	42	41	40	39	38	36
54	0.417	53	52	51	50	49	48	47	46	45	44	43	42	41	40	39	38
55	0.433	54	53	52	51	50	49	48	47	46	45	44	43	42	41	40	39
56	0.448	55	54	53	52	51	50	49	48	47	46	45	44	43	42	41	40
57	0.465	56	55	54	53	52	51	50	49	48	47	46	45	44	43	42	41
58	0.482	57	56	55	54	53	52	51	50	49	48	47	46	45	44	43	42
59	0.499	58	57	56	55	54	53	52	51	50	49	48	47	46	45	44	43
60	0.517	59	58	57	56	55	54	53	52	51	50	49	48	47	46	45	44
61	0.536	60	59	58	57	56	55	54	53	52	51	50	49	48	47	46	45
62	0.555	61	60	59	58	57	56	55	54	53	52	51	50	49	48	47	46
63	0.575	62	61	60	59	58	57	56	55	54	53	52	51	50	49	48	47
64	0.595	63	62	61	60	59	58	57	56	55	54	53	52	51	50	49	48
65	0.616	64	63	62	61	60	59	58	57	56	55	54	53	52	51	50	49
66	0.638	65	64	63	62	61	60	59	58	57	56	55	54	53	52	51	50
67	0.661	66	65	64	63	62	61	60	59	58	57	56	55	54	53	52	51
68	0.684	67	66	65	64	63	62	61	60	59	58	57	56	55	54	53	52
69	0.707	68	67	66	65	64	63	62	61	60	59	58	57	56	55	54	53
70	0.732	69	68	67	66	65	64	63	62	61	60	59	58	57	56	55	54
71	0.757	70	69	68	67	66	65	64	63	62	61	60	59	58	57	56	55
72	0.783	71	70	69	68	67	66	65	64	63	62	61	60	59	58	57	56
73	0.810	72	71	70	69	68	67	66	65	64	63	62	61	60	59	58	57
74	0.838	73	72	71	70	69	68	67	66	65	64	63	62	61	60	59	58
75	0.866	74	73	72	71	70	69	68	67	66	65	64	63	62	61	60	59
76	0.896	75	74	73	72	71	70	69	68	67	66	65	64	63	62	61	60
77	0.926	76	75	74	73	72	71	70	69	68	67	66	65	64	63	62	61
78	0.957	77	76	75	74	73	72	71	70	69	68	67	66	65	64	63	62
79	0.989	78	77	76	75	74	73	72	71	70	69	68	67	66	65	64	63
80	1.022	79	78	77	76	75	74	73	72	71	70	69	68	67	66	65	64

The Measurement of Water Vapor

The amount of water vapor in the air can be determined by measuring the temperature at which the air with a given quantity of water just becomes saturated when cooled.

This is the principle behind a very elaborate instrument known as the dew point hygrometer an instrument which, as the name implies, measures the dew point directly. In recent years this instrument has come to play an increasing role in the measurements of water vapor in the stratosphere where standard techniques fail due to low humidities. (At these elevations, one is actually measuring the frost point because the temperatures are below freezing.)

The dew point hygrometer works in the following manner: a polished surface is cooled by some means and its temperature is continuously monitored. The air immediately surrounding the polished surface is cooled by contact and as the air falls below the dew point temperature, the moisture will condense out on the shiny surface. The condensing water will cause the surface to grow dull. When the surface is warmed again, the dew will disappear. The average temperature at which the dew appears upon cooling and disappears upon warming is designated as the dew-point temperature. Knowing this and the ambient air temperature, one can determine the other water vapor parameters from tables.

Materials:

- A tuna fish can
- Thermometer
- Chunks of ice
- Warm water

Procedure:

Take a tin can whose sides are highly polished and fill to about one-third ($1/3$) with water and add small pieces of ice to lower the temperature gradually. Watch carefully for the appearance of dew on the outer surface of the cup. Be sure to keep your body and your breath away from the cup as the extra moisture from these will produce dew sooner than it would otherwise be obtained. Using a thermometer, which can also be used to stir the water insuring uniform temperatures, note the temperature at which the dew appears.

Once dew has appeared, gradually add small amounts of warm water and note the temperature at which the dew completely disappears. Repeat this several times, endeavoring to get the appearance and disappearance temperatures as close together as

possible. Take the average and record it as the dew point temperature. Record also the room temperature and using these obtain the relative humidity, the vapor pressure and the wet bulb temperature for the room.

To check the dew point temperature you received with the dew point hygrometer, a small psychrometer can be constructed using two household alcohol thermometers. (See sketch below). An ideal wick for the wet bulb would be an athletic shoe lace cut to a one-inch length and tied to the bulb of the thermometer with thread.

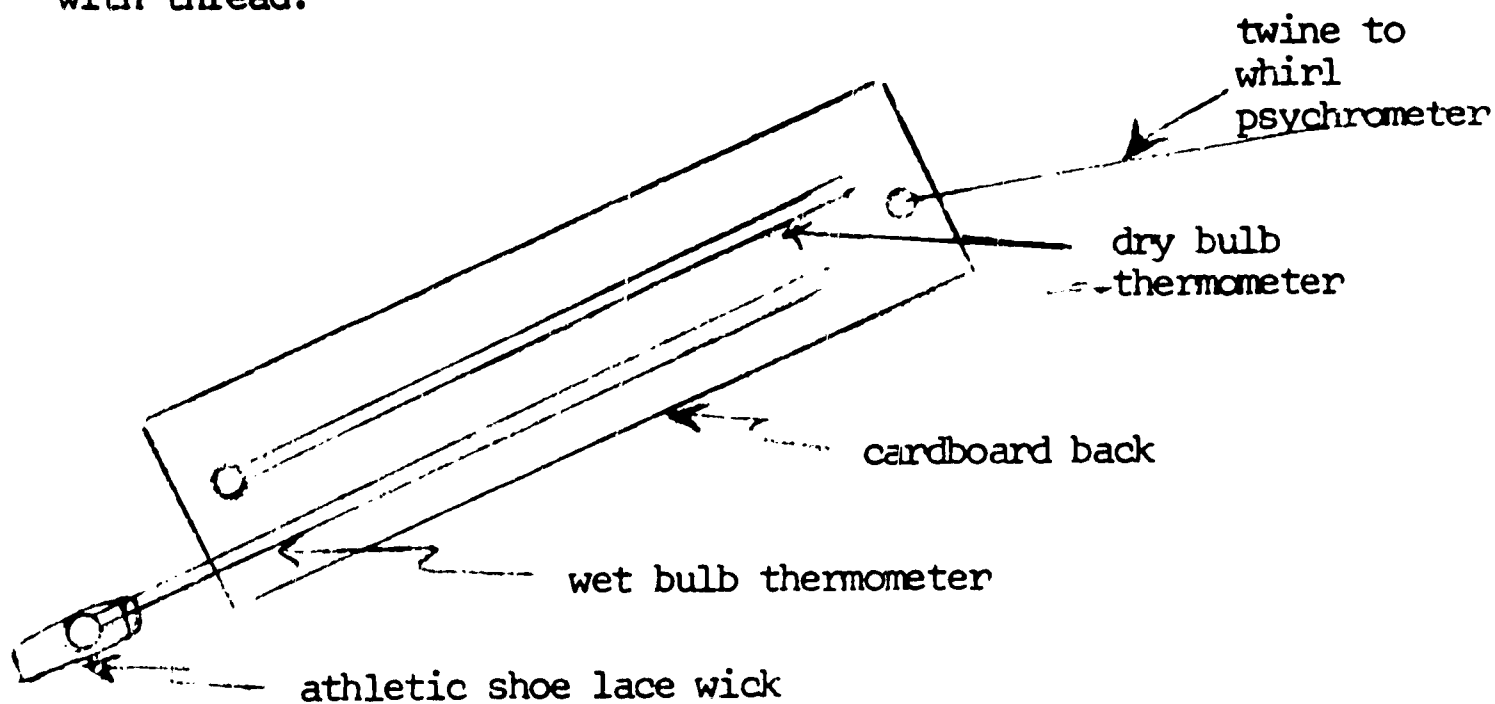

Questions:

1. What do you obtain for the following?

- dew point temperature _____
- relative humidity _____
- wet bulb temperature _____
- vapor pressure _____

2. Take your sling psychrometer and determine:

- dew point _____
- relative humidity _____
- vapor pressure _____
- wet bulb temperature _____
- dry bulb temperature _____

3. Discuss how the results of questions #1 and #2 compare and why they should or should not differ.

COMMENTS:

The exercises related to the measurement of water vapor were well accepted in their present form. The feeling was, however, that the subject could be carried further with emphasis upon the water vapor in the air rather than its measurement. It was suggested that measurements be taken at different times during the day and under differing weather conditions. In this manner the student would be able to relate this parameter to current weather conditions.

Pressure and Its Measurement

Not long after the thermometer was invented, Torricelli, in 1643, found that he could literally weigh the atmosphere by balancing it against a column of mercury in an evacuated tube. Torricelli directed one of his associates to fill a long tube with liquid mercury and invert it into a disk containing mercury. Torricelli was then able to show that the weight of the column of mercury remaining in the tube was equivalent to the weight of the atmosphere.

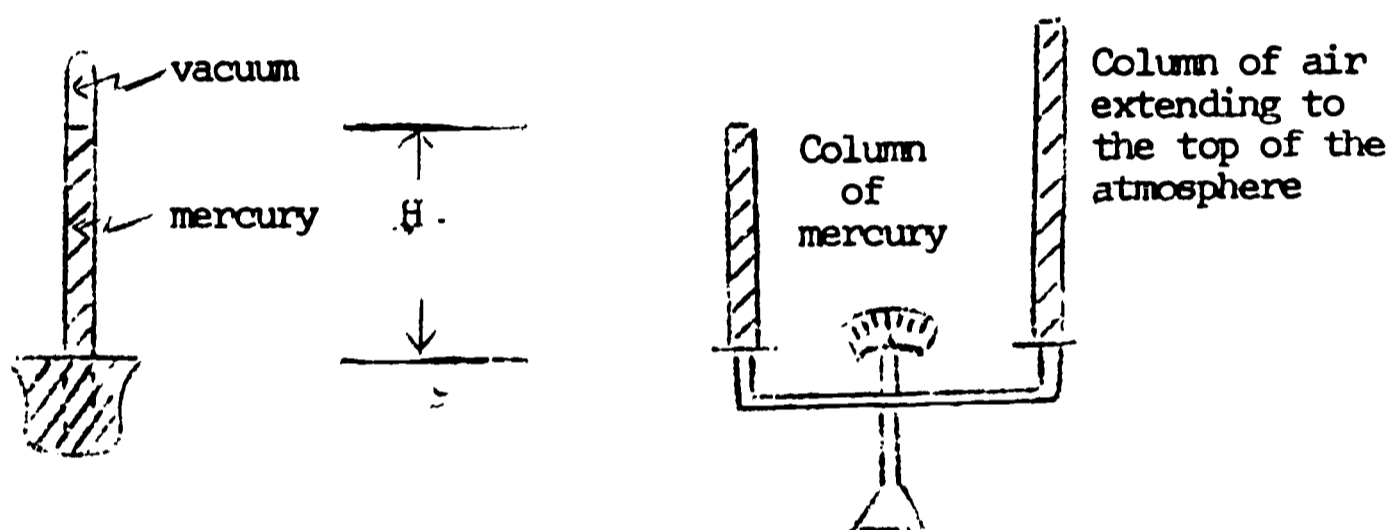

FIGURE 1

At sea level under normal conditions the height of the column of mercury is 29.92 inches. This means that a column of mercury 29.92 inches is equal to the weight of the overlying atmosphere.

The height of the column of mercury required to balance the weight of the air column above becomes less and less as one ascends in the atmosphere and, in fact, the column shortens about one inch for every 1000 feet of altitude in the lower part of the atmosphere. At 18,000 feet the column of mercury has shortened to roughly half its original height.

There are two types of pressure measuring instruments used: the mercurial barometer and the aneroid barometer. The mercurial barometer is as described above. The aneroid barometer consists of a partially evacuated cell made from a thin corrugated metal for flexibility.

The cell expands as the pressure of the environment falls and contracts as the pressure of the environment increases. One side of the cell is fixed and the other is connected to a pointer which after being calibrated registers the ambient air pressure. (See Figure 2)

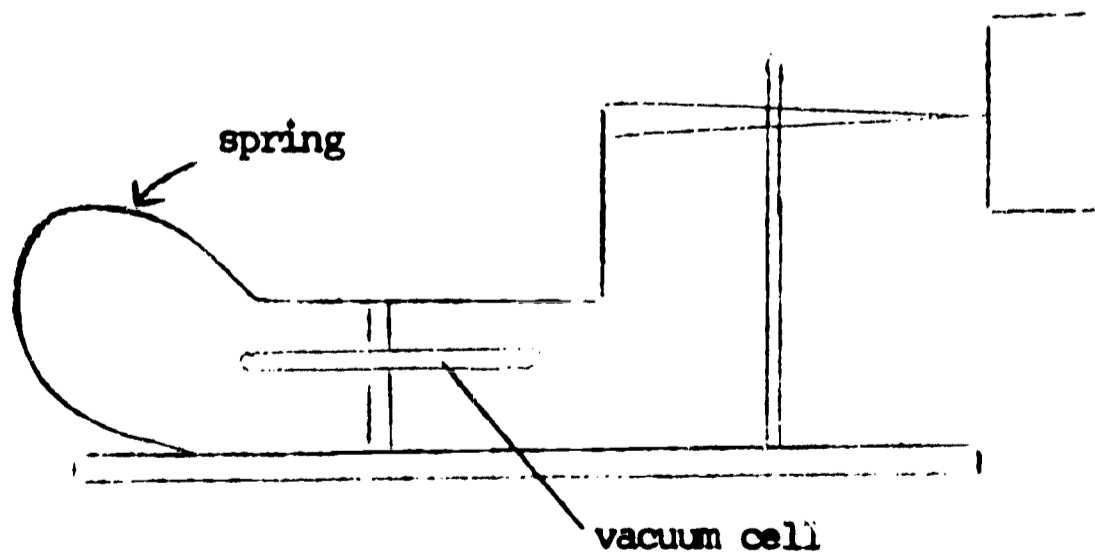

Aneroid Barometer

FIGURE 2

The pressure read at a station is called the station pressure. This pressure is corrected for the temperature, the height above sea level and the latitude to obtain the sea level pressure for the station. This corrected pressure is the pressure the station barometer would read if the station were located at sea level and were at 45 degrees north latitude.

In addition to the variation in pressure with height, pressure changes with time due to the diurnal variations and dynamic variations. The diurnal variations are due to the atmospheric tides which are strongest in low latitudes. The primary maximum due to the atmospheric tide occurs at 10 a.m., the secondary maximum at 10 p.m., the primary minimum at 4 p.m., and the secondary minimum at 4 a.m. The dynamic variations in pressure are due to the pressure systems (i.e., the highs and lows) that influence our weather from day to day.

Pressure is usually measured in inches of mercury on the barometer, but for certain meteorological purposes the millibar is used. (In the laboratory pressure is also indicated by millimeters.) Standard sea level pressure is 29.92 inches, 1013.25 millibars or 760 millimeters. Only the millibar is a true unit of pressure, the other two are units of length.

The relation between the pressure and the height of a column of fluid exerting this pressure is given by

$$p = \rho gh$$

where

- p = Pressure due to the fluid
- ρ = the density of the fluid
- g = acceleration due to gravity
- h = the height of the column of the fluid

As an example calculation: suppose a column of mercury is 76 centimeters high. What is the pressure exerted by this column of mercury?

Using:

$$p = \rho gh$$

$$\rho = 13.6043 \frac{\text{gms}}{\text{cm}^3}$$

$$g = 980 \frac{\text{cm}}{\text{sec}^2}$$

$$h = 76.0 \text{ cm}$$

$$p = \left(13.6043 \frac{\text{gm}}{\text{cm}^3} \right) \left(980 \frac{\text{cm}}{\text{sec}} \right) (76.0 \text{ cm})$$

$$\begin{aligned} p &= 1,013,250 \text{ gm } \frac{\text{cm}}{\text{sec}^2} \cdot \frac{1}{\text{cm}^2} \\ &= 1,013,250 \frac{\text{dynes}}{\text{cm}^2} \end{aligned}$$

Recall, a dyne = $\text{gm } \frac{\text{cm}}{\text{sec}^2}$

We also defined the bar as: $1 \text{ bar} = 10^6 \frac{\text{dynes}}{\text{cm}^2}$, and the millibar as:
 $1 \text{ millibar} = 10^3 \frac{\text{dynes}}{\text{cm}^2}$; therefore, we can write the above as:

$$\begin{aligned} p &= 1,013.25 \times 10^3 \frac{\text{dynes}}{\text{cm}^2} \\ &= 1,013.25 \text{ millibars} \end{aligned}$$

In oceanography, use is made of the decibar because this is roughly the pressure exerted by one meter of water. Consider a column of water one meter high (100 centimeters) and having a cross sectional area of one square centimeter. Since the density of water is roughly one gram per cubic centimeter, this column of water has a mass of 100 grams. The acceleration due to gravity is 980 cm/sec^2 .

$$\text{pressure} = \frac{\text{force}}{\text{area}} = \frac{\text{mass acceleration}}{\text{area}}$$

We shall assume 980 is approximately equal to 1000.

$$\begin{aligned} \text{pressure} &= \frac{100 \text{ gms}}{\text{cm}^2} \cdot \frac{1000 \text{ cm}}{\text{sec}^2} \cdot \frac{1}{\text{cm}^2} \\ &= 10^5 \frac{\text{gm cm}}{\text{sec}^2} \cdot \frac{1}{\text{cm}^2} \\ &= 10^5 \frac{\text{dynes}}{\text{cm}^2} \end{aligned}$$

Since 1 decibar = $10^5 \frac{\text{dynes}}{\text{cm}^2}$

Then, the pressure of 1 meter of water roughly equals 1 decibar.

Problem 1

Suppose we know that the atmospheric pressure is 1013.25 millibars, and we wish to construct a barometer using water instead of mercury. Using the equation $p = \rho gh$, what will be the height h of the column of water necessary to balance the pressure of the atmosphere? The density ρ of water is 1 gm/cm^3 .

Problem 2

The mean depth of the oceans is four thousand meters. What is the pressure at this mean depth in decibars?

Problem 3

At what depth below the surface of the ocean would you expect to find a pressure of two atmospheres? (i.e., 20,265 decibars)

Experiment:

Pour some oil into one side of a U-tube and then water into the other side. Allow a column of oil to be 5-10 cm high. It is not necessary to have the liquids meet at exactly the bottom of the U-tube. One can think of the water as representing the mercury in a barometer and the oil the atmosphere. The total pressure on either side must remain the same. (See sketch.)

Using a density of 1 gm/cm^2 for the density of water calculate the density of the oil.

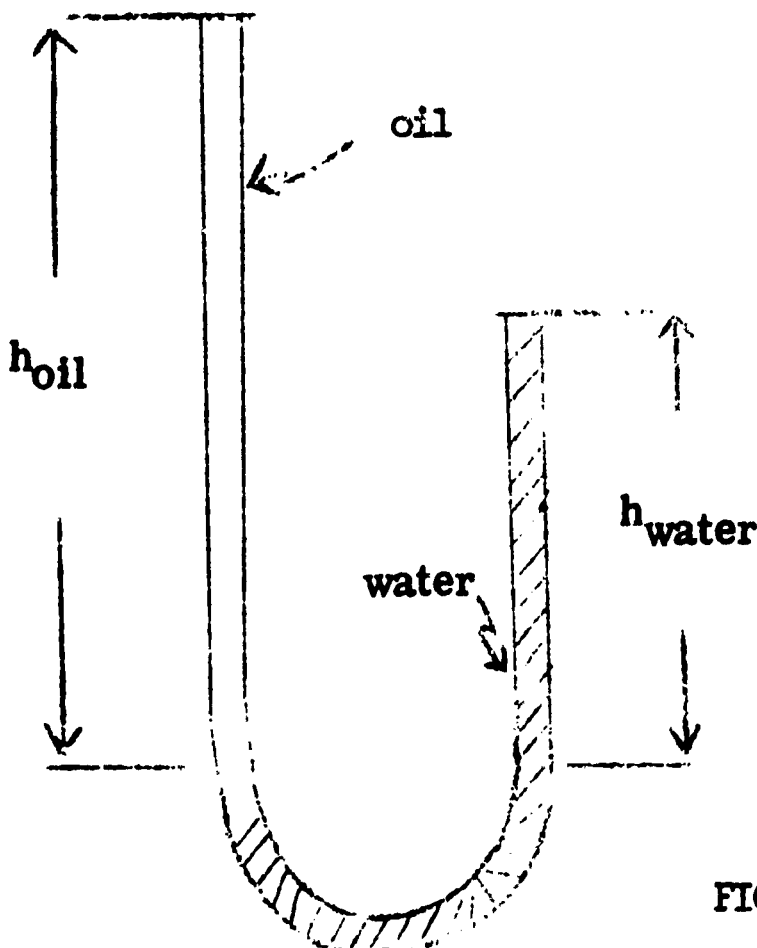

Pressure is the same on either side.

$$P_{\text{oil}} = \rho_{\text{oil}} g h_{\text{oil}}$$

$$P_{\text{water}} = \rho_{\text{water}} g h_{\text{water}}$$

$$\rho_{\text{oil}} = \rho_{\text{water}} \cdot \frac{h_{\text{water}}}{h_{\text{oil}}}$$

FIGURE 3

General Circulation--Winds

Wind is the flow of air. The movement may be vertical, horizontal, or both. Vertical and horizontal motions of air affect the flight of aircraft. In addition these air motions bring about changes in flying weather because they affect the distribution of pressure, temperature, moisture, and other factors.

The conditions of wind and weather occurring at any specific place and time are connected with the large-scale general circulation in the atmosphere. The problem of formulating a theory of the general circulation capable of accounting for the major features observed is one of the most difficult questions in meteorology. At present there is no universally accepted general theory which takes into consideration all the observed properties of the atmospheric circulation.

There are, however, a number of principles which must be satisfied by the general circulation and which deserve attention, and there are certain portions of the circulation which seem to be capable of a fairly simple physical explanation.

Effects of Sun's Heat

We know that the equatorial regions received more solar energy than do the polar areas. Also, we know that, at the equator, the radiational heat gained is greater than the radiational heat losses, while the reverse is true at the poles. Thus if radiation were the only factor, the equatorial regions would become increasingly warmer and the polar regions would become increasingly colder. However, this is not in accord with our observation, and therefore other mechanisms must exist for equalizing the heat excesses and deficiencies. This transfer of heat energy, which must be brought about, can only be accomplished by the actual transport of air from one latitude to another. Hence there must be some systematic north-south circulation in the atmosphere.

Since there is no net accumulation of air at a given latitude, the north-south movement of air must take place in such a manner that as much air crosses each latitude line in one direction as in the other. If such a circulation took place on a uniform non-rotating earth, the heating at the equator would cause the air at lower levels to expand upwards, and the cooling at the pole would cause the air at lower levels to contract. This would produce a low pressure in the upper levels over the poles and a higher pressure in upper levels over the equator.

Air in the upper levels would then begin to move from the equator (high pressure) toward the poles (lower pressure). This motion would result in a rise in the sea-level pressure at the pole and a reduction at the equator, since the sea-level pressure is a measure of

the weight of air above sea level. This pressure gradient (change of pressure with distance) would then result in a southward flow of air in the lower levels. Figure 1 represents the flow that would exist on a uniform non-rotating earth. However, since the earth rotates, other forces affect the air circulation over the globe.

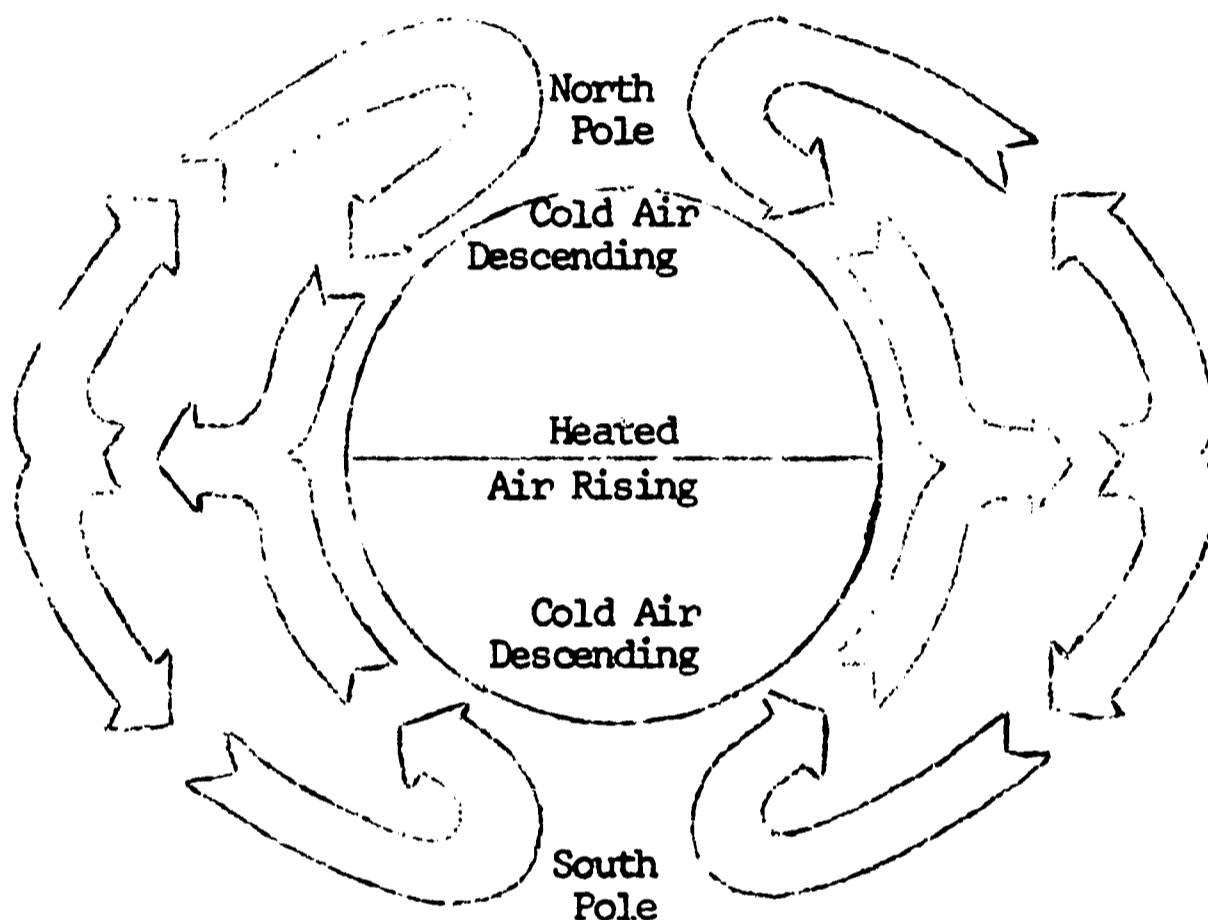

FIGURE 1

Other Effects

Let consideration be given to a band of air around the earth at 30° Latitude (fig. 2), moving with the rotating earth. It is at rest with respect to an observer standing on the earth. If this band is moved northward to 60° , the band will decrease in radius from 2,200 miles to 1,500 miles.

The result is similar to that found in the familiar example of a heavy object at the end of a string being whirled around in a circle. As the string is shortened, the object will tend to rotate faster and faster. In like manner the band of air decreasing in radius as it moves northward will increase its speed of rotation and, instead of being at rest with respect to the earth at 60° latitude, will now appear to an observer on the surface as a wind from the west. If, however, a ring of air at, say, 60° N. latitude,

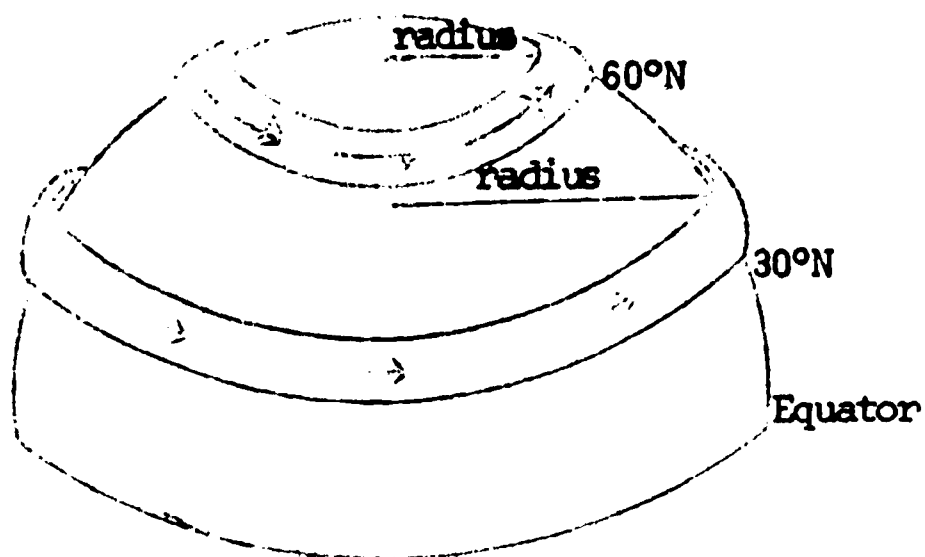

FIGURE 2

originally at rest relative to the earth is displaced toward the equator, the ring of air will increase in radius and will decrease in its speed of rotation. Thus there will then appear to be a wind from the east relative to the surface. These relative winds would be of very high speed; for example, in moving a band of air from 30° to 60°, the relative speed at 60° would be about 185 m. p. h. We know, however, that this is not the case and other factors, such as friction, severely limit this effect.

Another force acting on the atmosphere is an apparent force brought about by the rotating earth. It is called the "Coriolis force." This apparent force causes a deflection of the wind to the right in the Northern Hemisphere and to the left in the Southern Hemisphere. The Coriolis force can be illustrated as follows: start rotating the turntable on a phonograph record player (fig. 3); then with the use of a ruler and a piece of chalk quickly draw a "straight" line from the center to the outside edge of the rotating turntable. To the person drawing the line, the chalk traveled in a straight line.

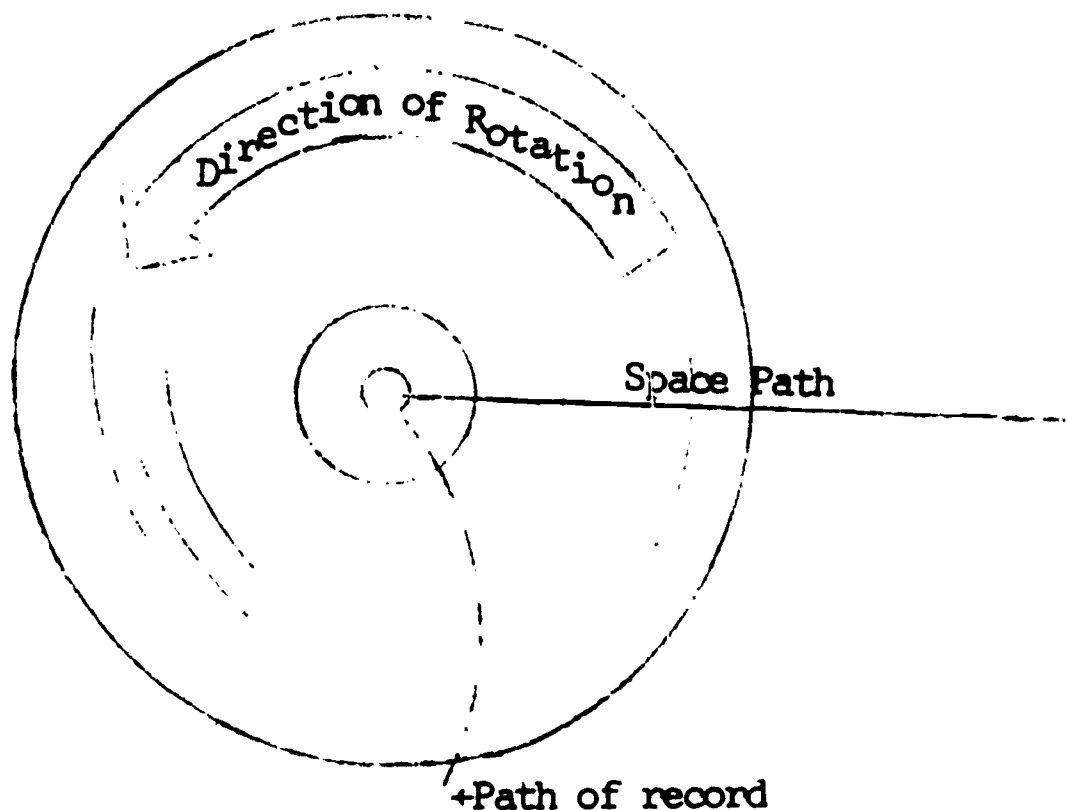

FIGURE 3

If the record is then stopped, the line on the record will not be straight, but will be curved. An apparent force has caused a deflection opposite to the direction of rotation. It is this apparent force which is called the Coriolis force. This apparent force is strongest at the poles and decreases to zero at the equator. It also varies as the wind speed so that, as the speed increases, the Coriolis force increases. Thus, as the air moves northward from the equator, it is deflected to the right and finally is no longer moving northward, but from west to east. This allows the air to pile up in the so-called "horse latitudes" (around 30° north latitude) and produces a high pressure zone. The air moving southward out of the horse latitudes is also deflected to the right and becomes the "northeast trades," and results in east winds at the equator.

In the polar regions a similar process is in operation with the southward moving polar air being deflected so as to become an east wind.

Air from the belt of high pressure at latitude 30° is forced northward and deflected so as to become a west wind, thereby producing the so-called "prevailing westerlies" of the middle latitudes. When this air meets the polar air, the polar front is formed. Here the westerly current overlays the easterly polar air current at about latitude 60° north. Figure 4 shows the general circulation on a uniform rotating earth--that is, an earth assumed to have an even surface everywhere composed of the same material. Note that the upper portions of the westerlies near the polar front push northward above the polar front and settle over the pole due to cooling.

A steady-state circulation of the type shown in figure 4 could not be maintained since there must be a return flow into the tropics to maintain the air flow balance. The piling up of air in the polar regions steepens the polar front, and when it becomes unstable, the cold air rushes southward. This is called a polar out-break or cold wave.

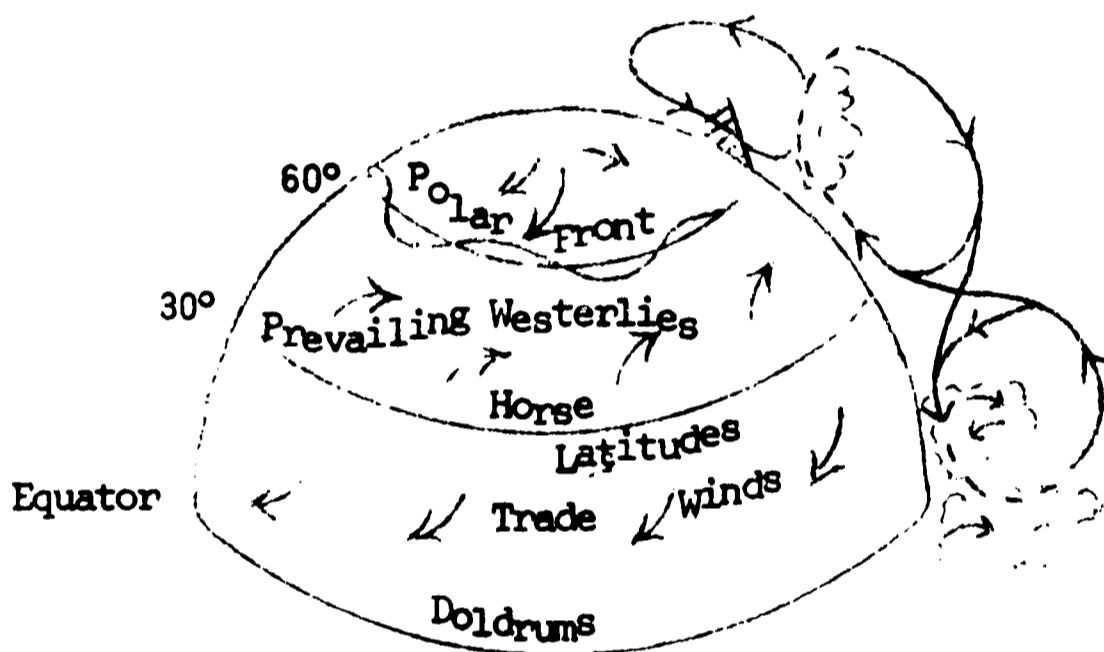

FIGURE 4

A polar view of the general circulation can be demonstrated in the laboratory in the following manner.

Materials:

- household 10 gallon bucket
- three flood lamps and drop cords
- record player
- tin can
- vegetable dye
- water
- ice cubes
- ring stand with clamps

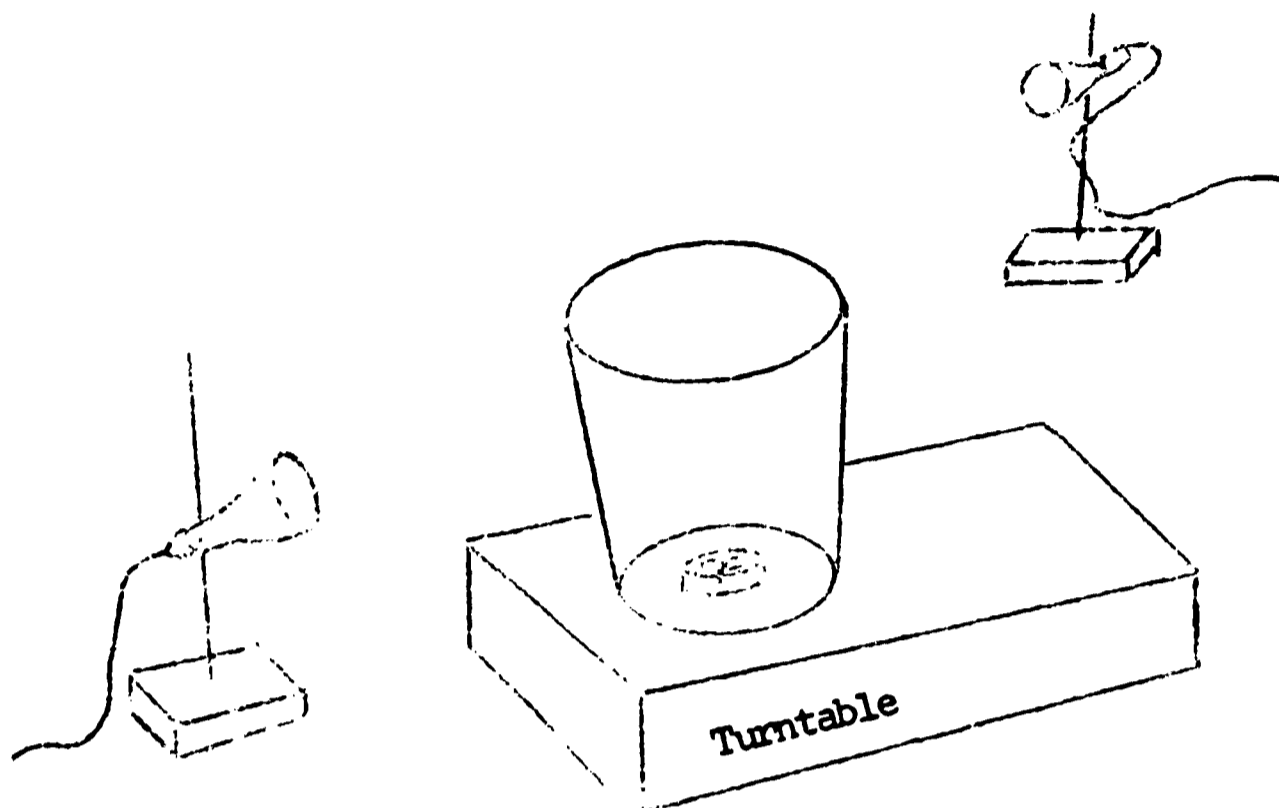

FIGURE 5

Procedure:

Set up the apparatus as in figure 5 placing about one inch of water in the bucket and a small tin can of ice chips in the center of the bucket. Turn on the flood lamps surrounding the pail and the turntable at 33 1/3 r. p. m. The ice chips in the center of the pail represent the cold source at the north pole and the flood lamps surrounding the outside of the pail represent the warm source at the equator.

Immediately after turning on the turntable place a few drops of vegetable dyes in the rotating fluid to trace the motions.

Questions:

1. Sketch the various stages of the circulation that you observe.
2. Explain the various patterns that you have sketched and discuss what they represent.
3. At what levels in our atmosphere does this demonstration correspond to?

4. Near the latter stages of development, your patterns may become extremely turbulent. How do you explain this?

(NOTE: This material was taken from Pilot's Weather Handbook, CAA Technical Manual, No. 104.)

Surface Weather Codes

One of the integral parts of operational meteorology is the observing, coding and transmitting of the weather for analysis. Weather observations are taken every hour for aviation purposes and every six hours for synoptic weather maps and forecasts.

All observations eventually reach the National Meteorological Center in Suitland, Maryland where, depending upon their nature, they are used in the analysis and forecasting. The derived meteorological charts and forecasts are then transmitted to all parts of the country and are eventually issued as local and regional forecasts.

This exercise will introduce the aviation weather code and the station model used on the surface weather map.

Exercise A:

Using the key to aviation weather reports and the sequence of aviation weather observations supplied, decode stations 1-5 on the sheet provided.

Exercise B:

Using the surface weather map station model and the sheet of weather symbols provided, complete the exercise for stations 1-3.

Exercise A

SYMBOL OR ELEMENT	STATION 1	STATION 2	STATION 3	STATION 4	STATION 5
VISIBILITY					
WEATHER					
OBSTRUCTION TO VISIBILITY					
PRESSURE					
TEMPERATURE					
DEW POINT TEMPERATURE					
WIND DIRECTION					
WIND VELOCITY					
ALTIMETER SETTING					

STATION #1 - ATL or Atlanta
 STATION #2 - TLH or Tallahassee
 STATION #3 - TPA or Tampa
 STATION #4 - ORL or Orlando
 STATION #5 - MIA or Miami

024 5A24280000
 ATL 2501000U07 093/69/64/1205/982 →ATL→9/34 PDK UR
 LSF →LSF→8/10IX 9/9UR
 FTY 200E1000/07 71/67/1507/982
 CSG 400/-015 085/75/69/0906/979/ 710 1201 83
 BY 450E100010RW-- 73/69/0705/978/ RB35
 VLD E200/010 76/72/1309/980-WLD→8/26UR
 TLH 400/012 084/77/70/1904/977
 CTY AMOS / 76/ 33/2202/976/000/
 CIV E200120010 097/72/70/0805/981/RE10/ 30301 86
 TPA S 250E1200/010 084/75/71/0204/977/TE54 MOVD N OCML LTGIC N RE38
 PIE 300/08 78/75/0306/977 TE36RE29 CB NE→PIE→8/31P
 FMY 200E100012R-- 091/78/74/1410/979/ 610 82
 EYW 120E450120012T 091/81/73/1212/979/ TB22 TRWU 4SSI 20SW
 MOVE W OCML LTGIC
 MIA S M1701000/08 102/79/71/1803/982 RE16/ RADAT 95139
 FLL 120/010 77/72/1804/981 BINOVC K NE
 PRI 1000U015 102/76/72/1804/982/OCML LTGIC DSNT CB NW/ 60500
 1932 80/80
 VRP 1801200U015 091/78/72/1806/979/ 71000 85→VRB→9/10
 MLB 200E100010 75/71/1807/980-MLB→9/32XX
 ORL 400E1200/015 097/79/72/1206/981/DSNT LTG NW
 MCO 800U010 80/70/0902/980/OCML DSNT LTG SW-NW-NE→MCO→9/8UR
 DAB 150E8001200/07R-- 098/73/71/2903/981/BINOVC RE10R43/ 60773 1178 83
 TIDE PLUS 002
 JAX 60E300/06R-- 098/76/72/1408/981/RB10 RADAT 92130 2331
 →JAX→9/21 STA XX
 SSI 1201000U08 091/76/71/1311/979/BINOVC/ 71402 80→SI→9/1UA
 SAV M1101704K 099/73/71/1406/982 RB01E46→SAV 9/31 S/N BLANK
 →9/13 SVN XX 9/30 HIN UR 9/32EN
 CHS E13060011006R- 110/71/68/1208/985/RADAT 00135 WR18→CHS→9/25 UR
 FLO 120E800/04R--HK 123/68/63/0705/989/ 61506 80
 NYR
 CRE 500E80007R-- 59/68/0000/E990
 CAE M501303R-F 114/68/68/1008/986
 AND S 90M1108007 111/70/66/0809/987/RE23/ 81500 76
 HM E70010 104/68/64/0905/985/ RADAT 50099
 MCN 250E100010 090/70/65/0907/980-MCN→9/4XX
 AMG E2007007RW-- 096/70/70/1105/981/BINOVC/ 60710 ONE 81 →AMGC9/14
 ACS M601001R-F 100/69/67/1009/982

KEY TO AVIATION WEATHER REPORTS

LOCATION AND TYPE OF REPORT	SKY AND CEILING	VISIBILITY AND OBSTRUCTION TO VISION	SEA LEVEL PRESSURE	TEMPERATURE AND DEW POINT	WIND	ALTIMETER SETTING	RUNWAY VISUAL RANGE	VISUAL RANGE	COORDINATES
MKC150M250	4R-K 132	58/56	1807	1993	RO4LVR20V40	/055			

SKY AND CEILING

Sky cover symbols are in ascending order. Figures preceding symbols are heights in hundreds of feet above station. Sky cover symbols are:
 ○ Clear: Less than 1% sky cover
 ⊙ Scattered: 0.1 to less than 0.6 sky cover.
 ⊕ Broken: 0.6 to 0.9 sky cover.
 ⊕ Overcast: More than 0.9 sky cover
 — Thin (When prefixed to the above symbols.)
 -X Partial obscuration: 0.1 to less than 1.0 sky hidden by precipitation or obstruction to vision (bases at surface)
 X Obscuration: 1.0 sky hidden by precipitation or obstruction to vision (bases at surface)

Letter preceding height of layer identifies ceiling layer and indicates how ceiling height was obtained. Thus:

- A Aircraft
- B Balloon (Pilot or Radar)
- D Estimated height of surface clouds on basis of persistence.
- E Estimated heights of non-surface clouds
- M Measured
- R Radiosonde Balloon or Radar
- U Indefinite height of cumiform ceiling layer or unknown height of cumiform ceiling layer unknown.
- W Estimated heights of surface clouds following numerical value indicates surface value.

VISIBILITY

Reported in Statute Miles and Fractions. (Variable)
WEATHER AND OBSTRUCTION TO VISION SYMBOLS

- | | | |
|-----------------|-----------------|---------------------|
| A Mist | F Fog | RW Rain Showers |
| AP Small Mist | GF Ground Fog | S Snow |
| BD Blowing Dust | H Haze | SG Snow Grains |
| BS Blowing Sand | IC Ice Crystals | SP Snow Pellets |
| B5 Blowing Snow | IF Ice Fog | SW Snow Showers |
| D Drizzle | K Smoke | T Thunderstorm |
| E Snow | L Drizzle | Z1 Freezing Drizzle |
| FR Snow Showers | R Rain | ZR Freezing Rain |

Precipitation intensities are indicated thus:
 -- Very Light; - Light; no sign) Moderate; ⚡ Heavy
WIND
 Direction in tenths of degrees from true north, speed in knots. 0000 indicates calm. G indicates gusts. Peak speed of gusts follows G or Q when squall is reported. The contraction WSHT follows by local time group in remarks indicates wind shift and its time of occurrence. Kts. x 1.15 = statute mi./hr.
EXAMPLES: 3x2° 360 Degrees, 2° Knots;
 3°G 40 360 Degrees, 2° Knots Peak speed in gusts 40 knots.

ALTIMETER SETTING

The first figure of the actual altimeter setting is always omitted from the report.

RUNWAY VISUAL RANGE (RVR)

RVR is reported from some stations. Extreme values for 10 minutes prior observation are given in hundreds of feet. Runway identification is provided. RVR reports are:

CODED PIREPS
 Pilot reports of clouds not visible from ground are coded with MSL height data preceding and/or following wavy cover symbol to indicate cloud bases and tops, respectively.

DECODED REPORT
 Kansas City: Record observation, 1500 feet scattered clouds, measured ceiling 2500 feet overcast, visibility 4 miles, light rain, smoke, sea level pressure 1013.2 millibars, temperature 50°F, dewpoint 50°F, wind 180°, 7 knots, altimeter setting 29.93 inches. Runway 04 left, visual range 2000 ft., variable to 4000. Pilot reports top of overcast 5500 feet.

TYPE OF REPORT

The omission of type-of-report data identifies a scheduled record observation for the hour specified in the sequence heading; the time of an out-of-sequence special observation is given as "95" followed by a time group (24-hour clock GMT) e.g., "95 5 0715-KM...". A special indicates a significant change in one or more elements. Local reports are identified by "LCL" and a time group. Locals are transmitted on local telewriter circuits only.

Exercise B

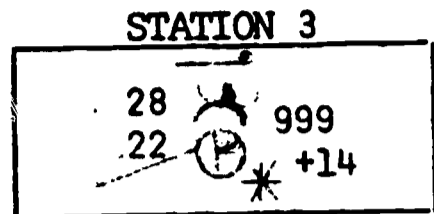
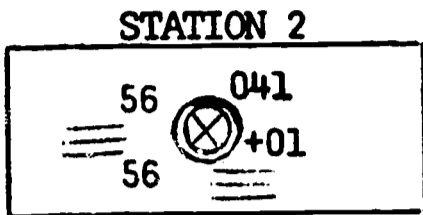
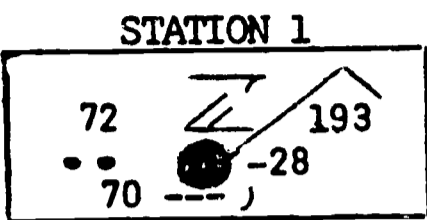

TEMPERATURE			
DEW POINT			
PRESSURE (Record in Full)			
HIGH CLOUDS			
MIDDLE CLOUDS			
LOW CLOUDS			
WIND DIRECTION			
WIND SPEED			
TOTAL AMOUNT ALL CLOUDS (in 10ths)			
PAST WEATHER			
PRESENT WEATHER			

SPECIMEN
STATION MODEL

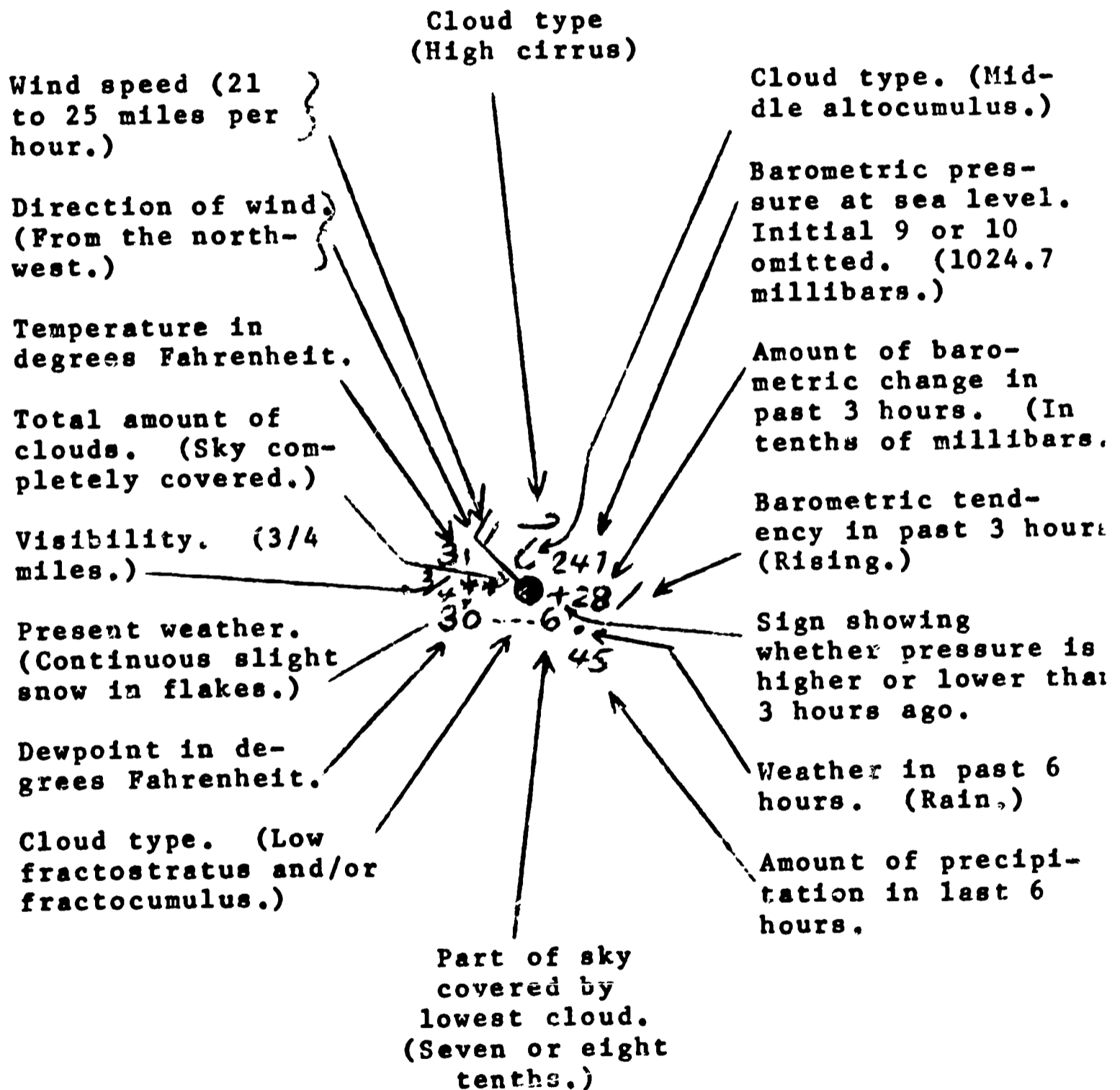

Scalar Field Analysis

One of the more valuable tools available to both meteorologist and oceanographers is the scalar analysis to aid in deriving the maximum amount of information from a spacial distribution of some property Q , which might be temperature, pressure, salinity or any other parameter.

A scalar analysis is the connecting of all points of equal value of the quantity Q by a line. In places where the data does not explicitly appear, we interpolate between surrounding values. Since in theory an infinite number of lines can be drawn, we usually pick an interval to draw for depending upon the data we are analyzing for. If, for example, a range of temperatures is only five or ten degrees, then, perhaps, we may wish to analyze for every two degrees or even every one degree to delineate the field. A range of one hundred degrees, on the other hand, might be better delineated by isotherms every twenty degrees.

These isopleths, lines of constant Q will never end abruptly in the middle of the chart but will close on themselves. They may end at the edge of your chart but this presupposes that if you had a larger chart the line would eventually close upon itself. In addition, a line will never intersect another of different value because this would imply, in the case of temperature, that the particular point in space had more than one temperature.

When the lines of constant quantity Q have been drawn and labeled, we can immediately pick off regions of high and low values. Often we indicate these as maximum (MAX) and minimum (MIN) areas respectively. Areas where the lines are closely spaced imply that the field is changing rapidly along a direction normal to these isopleths. In areas where only a few lines appear, no appreciable change occurs in any direction and the field is relatively homogeneous in this parameter.

Exercise:

Analyze the following scalar field for every twenty units using 820 as a starting line. Label the region of maximum Q as MAX and the region of minimum Q as MIN. Indicate where the field is changing most rapidly with distance.

Z	.760	.780	.779	.759	.737	.739	.753
.764	.792	.811	.807	.773	.739	.759	.785
.791	.818	.832	.820	.787	.751	.775	.803
.815	.841	.852	.833	.808	.794	.802	.823
.840	.866	.879	.856	.836	.829	.832	.846
.860	.884	.893	.868	.865	.861	.864	.873
	.873	.878	.879	.884	.891	.896	.903
							X

Determination of Salinity

The salinity of sea water is defined as the total amount of solid material in grams contained in one kilogram of sea water when all the carbonate has been converted to oxide, the bromine and iodine replaced by chlorine and all organic matter completely oxidized. Knowing the salinity of sea water is extremely important to the oceanographer and marine biologist because it affects the density, freezing point and light dispersion characteristics of the water. Knowing the salinity of sea water helps the oceanographer predict the behavior of the oceans' waters and helps the marine biologist determine what kind of plants and animals will be found in a given area.

As defined above, determination of salinity is a highly complex, time-consuming process. But since chlorine composes about 55% of the dissolved solids in sea water, and since the ratios of chlorine to other dissolved materials is considered to be constant, salinity can be determined by relating it to the chlorinity of the water.

Chlorinity is defined as the total amount of chlorine, bromine and iodine in grams contained in one kilogram of sea water, assuming that the bromine and iodine have been replaced by chlorine, and is related to salinity by

$$S (\text{‰}) = 0.030 + 1.805 \text{ Cl } (\text{‰})$$

where $S (\text{‰})$ is the salinity in parts per thousand and $\text{Cl } (\text{‰})$ is the chlorinity in parts per thousand.

To determine the chlorinity, a 10 ml sample of sea water is titrated with a solution of silver nitrate of known concentration. A solution of potassium chromate is used as an indicator and will turn a redish brown when the end point of the titration is reached. Titration results are calculated by means of the formula:

$$\text{Cl } (\text{‰}) = \frac{\text{ml AgNO}_3 \times \text{N of AgNO}_3 \times 35.46}{\text{ml Sample}}$$

Objective:

To determine the salinity of sea water using the Knudsen Method.

Materials:

1. 150 ml Erlenmeyer flask
2. Burette with clamp and stand
3. Potassium chromate indicator (8 gm K_2CrO_4 dissolved in 100 ml of distilled water.)
4. 0.25N solution of silver nitrate (42.47 gm $AgNO_3$ dissolved in 1000 ml of distilled H_2O .)
5. Sea water sample of unknown salinity
6. 10 ml pipette

Procedure:

Using the pipette provided, measure out 10 ml of the sea water sample and put it into your 150 ml flask. Add 4 drops of the potassium chromate indicator and swirl to mix evenly.

Fill the burette with the 0.25N silver nitrate. Make sure you accurately record the starting volume of solution in the burette.

Add silver nitrate to the flask, using the following procedure:

Stop when contents turn red, and stir solution with a glass stirring rod. Stir as vigorously as possible without losing any contents by spattering.

Add silver nitrate solution slowly - S L O W L Y.

Stop when solution turns orange-red and expel last drop from pipette and then stir vigorously.

Add silver nitrate solution V E R Y S L O W L Y, stirring almost continually.

Stop when solution barely loses lemon-yellow color and takes on an orange cast. Stir very vigorously without regard to spattering.

Endpoint is reached when:

- a. precipitate is white
- b. solution is dirty orange by reflected light
- c. colors are retained after 10 seconds of stirring.

Observations:

1. ml's of Silver nitrate used 17.7
2. Value calculated for chlorinity 15.7 ‰
3. Value calculated for salinity 28.4 ‰
4. Write the reaction for the titration.

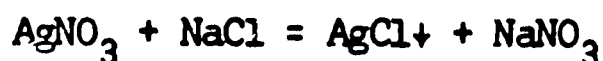

$$\text{Cl } \text{‰} = \frac{17.7 \text{ ml} \times 0.25 \times 35.46}{10 \text{ ml}} = 15.7 \text{‰}$$

$$\text{S‰} = (1.805 \times 15.7) + 0.03 = 28.38 \text{‰}$$

COMMENTS:

Caution: Silver nitrate solutions are colorless, but will darken with exposure to light (leaving stains). Therefore, keep away from hands and clothing. Immediately wash off any suspected contact. Clean up all spills at once.

In place of the burette, a pipette may be used, however, the results will not be as accurate. When using a burette it may be desirable to use a Silver nitrate solution whose normality is 0.156. In this way the number of ml of solution used per 10 ml of Sample is numerically equal to the salinity minus .030‰.

The Density of Sea Water

The density, ρ , of water is dependent on three variables: (1) the temperature, (2) the salt content or salinity, and (3) the pressure. (For these labs we will consider the pressure to be that of sea level and we will not consider it as a variable.)

The density variations in water are small and for this reason it is more convenient to express the changes by an anomaly [i.e., the amount larger than the reference value (1.00000)]. Moreover, to make these density anomalies easier to work with they are multiplied by 1000. So, we have σ (sigma) the density anomaly of water.

$$\sigma = (\rho - 1) \cdot 1000$$

We will now proceed to examine the dependence of density, or more precisely, the density anomaly, σ , on temperature and salinity.

Tables of σ for different temperatures and salinities are attached to this laboratory.

PART A: Using this table plot on linear graph paper σ for increments of 5 ‰ salinity for constant temperatures of 0°, 10°, 20°, and 30°C. You should have four lines on the graph.

Question: Is the dependence of density with salinity linear (a straight line)?

Answer: The dependence of density with salinity is linear.

PART B: On another piece of graph paper plot σ for increments of 5° for constant salinities of 0, 10, 20, and 30 ‰.

Question: If the dependence of density with temperature linear?

Answer: The dependence of density with temperature is not linear. There is an increase in density with a decrease in temperature until a maximum is reached. After the maximum is reached, density decreases with a decrease in temperature.

PART C: On a third piece of graph paper label salinity, 0 through 30 ‰, on the long axis and temperature on the short, -5° to 5°. Plot the temperature of the density maximum versus salinity.

Questions: 1. If a water sample is cooled from 10° to 9° and has a salinity of 30 o/oo, what will happen to the cooled sample? Will it float or sink? Why?

Answer: The water sample will sink because the density will increase with a decrease in temperature until -2.47°C .

2. What would happen to this water sample if it were cooled from 1° to 0° ?

The water sample will sink because the density will increase with a decrease in temperature until it becomes ice at -1.62°C .

3. What if the salinity were 10 o/oo and cooled 10° to 9° ?

Again, the water would sink for the same reason as above.

4. What if the salinity were 10 o/oo and cooled 1° to 0° ?

In this case the water would rise. The maximum density for 10 o/oo salinity is 1.85°C . Further cooling decreases the density until the sample freezes at -0.534°C .

PART D: On this same graph plot the freezing point of water for different salinities. Note that this line crosses the temperature of maximum density at about 25 o/oo.

Questions: 1. Do you think that this salinity might be significant in marine processes for the formation of ice?

Yes. For salinities greater than 25 o/oo, density increases with a decrease in temperature up to the freezing point. This means that for sea water to freeze the entire column must be at the freezing point.

2. When ice forms on the water surface, what will the bottom temperature be for water of 30 o/oo?

The temperature at the bottom will be -1.62°C . It is probable that the water at the bottom will not freeze because of the latent heat of fusion. It is possible that, because the salinity of the water column will increase as the ice forms, the temperature will drop below -1.62°C but this is not probable because the layer of ice will insulate the column.

3. For 10 o/oo salinity?

The temperature will be 1.85°C as a maximum. However, it could be anywhere between 1.85° and -0.543°C , depending upon the degree of mixing.

4. Would you expect ice to form faster in a harbor (100 meters deep) if the salinity were 35 o/oo or 15 o/oo? Why?

The ice would form faster for 15 o/oo. This would happen because the maximum density is reached before the freezing point, allowing the colder water to rise to the surface where it could be cooled to the freezing point.

5. How would you explain that in the Antarctic Ocean ice does not always form even though the temperature is well below freezing for long periods of time?

The colder water near the freezing point would be more dense and sink allowing the warmer, less dense water to rise. If there were no currents to take into consideration and the Antarctic Ocean was considered to be an isolated body of sea water, the entire volume would have to be cooled to freezing for ice to form. Assuming that the latent heat of fusion could be given up just as easily from the deep water as from the surface water, the entire ocean would freeze simultaneously from top to bottom.

Conclusions:

1. As a rule for waters of less than 25 o/oo salinity, decreasing the temperature increases the density to a maximum; further cooling decreases the density until the freezing point is reached.

2. For waters with a salinity of 25 o/oo or greater, a decrease in temperature increases the density until the freezing point is reached.

3. Density of water is increased with an increase in salinity.

4. For ocean waters to freeze, the entire body must reach the freezing point.

σ For Various Temperatures and Salinities

T °C	S o/oo							
	0	5	10	15	20	25	30	35
-5	-.7	3.3	6.7	11.0	15.0	19.0	22.9	26.9
0	0	4.0	7.5	11.9	16.0	20.1	24.1	28.2
5	-.1	3.8	7.3	11.7	15.7	19.6	23.6	27.6
10	-.33	3.6	7.0	11.4	15.3	19.1	23.0	26.9
15	-1.0	2.9	6.4	10.5	14.4	18.2	22.0	25.9
20	-1.7	2.1	5.8	9.6	13.5	17.2	21.0	24.8
25	-2.7	1.0	4.7	8.4	12.2	15.8	19.6	23.4
30	-4.4	-0.5	3.2	7.0	10.8	14.4	18.2	22.0

T of max ρ	3.98	2.94	1.85	0.72	0.35	1.40	-2.47	-4.27
-----------------	------	------	------	------	------	------	-------	-------

T of Freezing	0	-.267	-.534	-.803	-1.05	-1.34	-1.62	-1.896
---------------	---	-------	-------	-------	-------	-------	-------	--------

Temperature-Salinity Correlations

It has been found that water in any particular location in the ocean remains quite distinct as far as the temperatures and salinities of the water masses in the water column are concerned. This is especially apparent when water temperatures are plotted against salinities.

As we discovered earlier, water temperature and salinity determine the water density. Thus, on this same graph of temperature and salinity, we can determine the water density. Moreover, it must be remembered that in a water column the density must always either stay the same or increase as one goes deeper. This gives us a quick check on the temperatures and salinities measured in a water column.

Object: To investigate the temperature-salinity correlations of a water column.

Material: T-S diagram paper

Procedure: Look at the T-S diagram paper in front of you. Notice that salinities are labeled from left to right on the horizontal axis, and temperature from the bottom to the top on the vertical axis. Notice also that there is a third set of lines running diagonally across the paper. These lines are called isopycnals and represent lines of equal density.

- A. 1. Put a point on this diagram at $T = 22.5^{\circ}\text{C}$, $S = 37.45\text{o}/\text{oo}$. What is the density anomaly?

Answer: $\sigma_T = 26.0$

2. Put a point at $T = 8.6^{\circ}\text{C}$, $S = 33.5\text{o}/\text{oo}$. What is the density anomaly?

Answer: $\sigma_T = 26.0$

3. How many combinations of temperature and salinity have this same density anomaly?

Answer: An infinite number.

4. Assume that at a given location three water samples were taken, but the scientist forgot to label which sample was taken at which depth. The samples were taken at 0-meters, 50-meter, and 100-meter depths. The temperatures and salinities were $(20^{\circ}, 35.5\text{o}/\text{oo})$,

(8°, 35.00/oo) and (15°, 36.50/oo). Remembering that for the water column to be in equilibrium the density must always increase with depth, which water sample was taken at which depth?

Answer: 20°, 35.50/oo at 0 meters
15°, 36.50/oo at 50 meters
8°, 35.00/oo at 100 meters.

- B. 1. On the T-S diagram plot the points of temperatures and salinity taken at HIDALGO STATION #5 in the Gulf of Mexico listed on the next page. Beside each point put the depth at which that water was found. Notice, at the surface the points fall on top of each other.
2. Connect these points with a smooth line going from 0 meter depth to 2,696 meters. Does this smooth line always cross the isopycnals from low to high value? Does it ever go toward one isopycnal then bend away from it? If your answer is "yes" to either of these questions, check your plotting as you have made a mistake. What you now have is a temperature-salinity correlation diagram which gives the temperatures and salinities of all the waters from 0 to 2,696 meters at this station. Make a guess as to how deep one would have to go to find water whose temperature is 13.0°.

Answer: Between 257 and 344 meters (315).

3. Notice that there are two bulges in this curve. One is a salinity maximum and the other is a salinity minimum. These are quite common and are used to trace the circulation of waters in the ocean.

The water which creates the salinity maximum comes from the tropical Atlantic. As this water moves away from its origin toward the Gulf of Mexico, it gets mixed with waters above and below it having its salinity and temperature decreased. Originally, this water was (22.6°, 37.00 o/oo).

For waters to mix, they must be in contact with one another. Mixing occurs along isopycnals on the T-S diagram. This is so, for if the densities of the mixing water masses were not the same, they would not be in contact with each other.

4. The water which was mixed to create the salinity minimum originally had a salinity of 34.2 o/oo. What was its temperature?

Answer: 2.0°C

5. Where in the world might this water have been formed?

Answer: Antarctic Ocean from melting ice.

HIDALGO CRUISE 1962 Station 5

<u>Depth M</u>	<u>Temp. °C</u>	<u>Sal. c/oo</u>
0	22.70	36.39
9	22.70	36.39
21	22.67	36.39
44	22.67	36.39
65	22.64	36.39
87	22.52	36.39
130	22.62	36.39
173	20.15	36.46
214	17.86	36.36
257	15.71	36.04
344	12.45	35.55
437	10.02	35.20
527	8.41	35.01
706	6.31	34.88
886	5.30	34.91
1341	4.32	34.96
1818	4.24	34.97
2300	4.23	34.97
2696	4.27	34.97

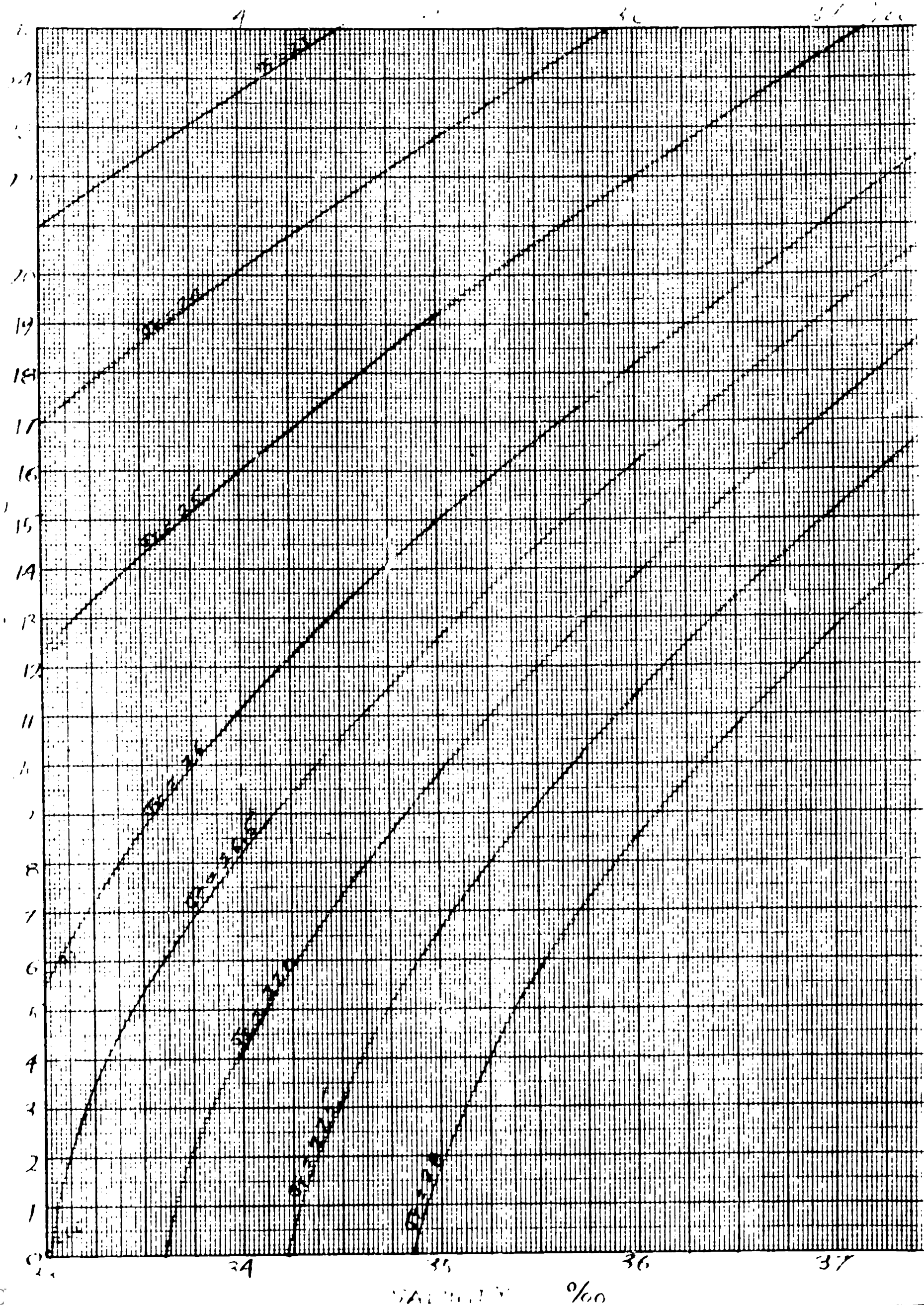

Surface Waves

Surface waves are the periodic variations in the level of the surface of a fluid. They are a re-occurring phenomenon which, ideally, always have the same height, wavelength and, if the depth of the fluid is constant, the same period (time for a crest to travel one wave length.)

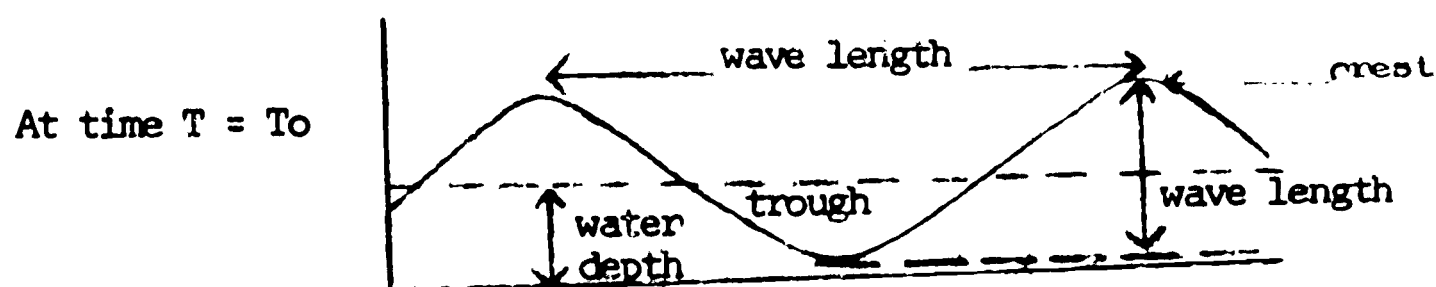

Surface waves can be divided into two main classifications. SHALLOW WATER WAVES are waves which travel in water which has a depth less than $1/2$ the wave length of the wave. The phase velocity at which these waves travel is dependent upon the depth of the water and can be calculated by the formula

$$c = \sqrt{gh}$$

where c is the phase velocity, g is the acceleration of gravity (9.8 meters per second squared), and h is the depth of the fluid.

DEEP WATER WAVES are waves which travel in water which has a depth greater than $1/2$ the wave length of the wave. The phase velocity of these waves is dependent upon the wave length of the wave and can be calculated using the formula

$$c = \sqrt{\frac{g}{\frac{2\pi}{\lambda}}} \quad \left(\frac{2\pi}{\lambda} = \text{wave number} \right)$$

where c is the phase velocity, g is again the acceleration due to the force of gravity, and λ is the wave length of the wave. Since λ is in the denominator of the denominator of a complex fraction, a more useful form of the above formula is given below.

$$c = \sqrt{\frac{g\lambda}{2\pi}}$$

Object:

To study reflection, diffraction and refraction of surface waves and to calculate the phase velocity of a shallow water wave.

Materials:

1. Ripple tank
2. Long wave channel
3. Paraffin blocks
4. Glass plates
5. Plastic triangles
6. Water

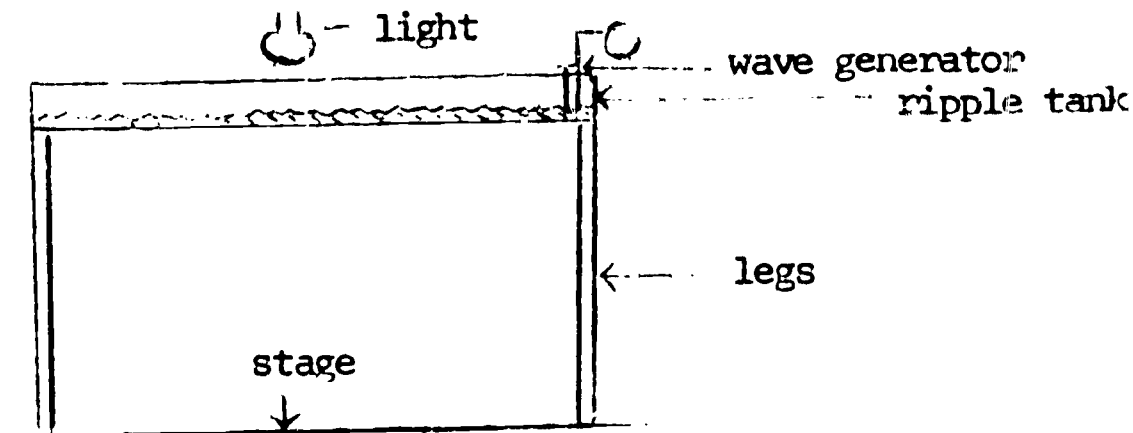

Ripple Tank

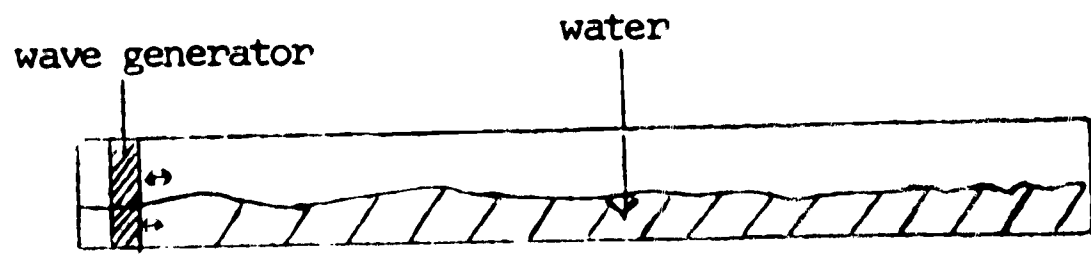

Long Wave Channel

Procedure and Observations:

A. Reflection

Procedure: Observe and describe (drawings with a sentence or two) waves which hit a wall (paraffin blocks) head on. (Clapotis may be observed.)

Observation: The waves hitting the wall straight on were reflected back and superimposed on the incident waves. This set up a standing wave or Clapotis which, theoretically, should have an amplitude twice that of the incident wave. (See sketch below)

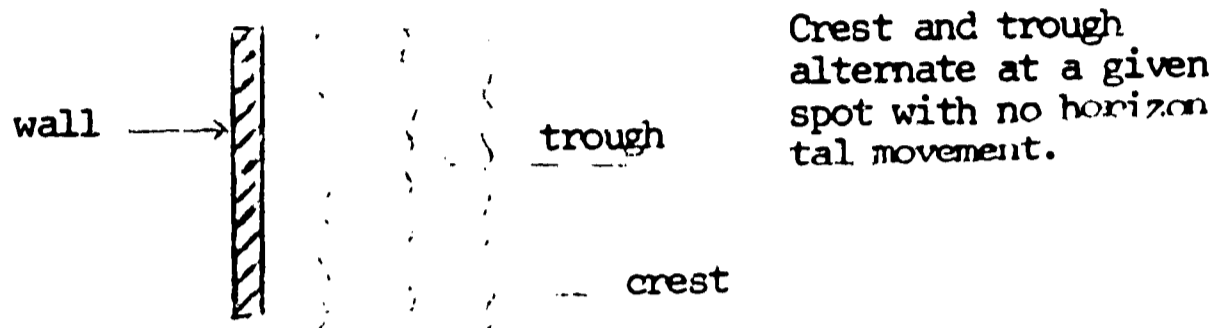

Procedure: Observe and describe waves which hit a wall at an angle.

Observation: Waves that hit a wall at an angle were reflected at an angle equal to the incident angle. The reflected waves were superimposed on the incident waves causing what is commonly referred to as a "cross-chop".

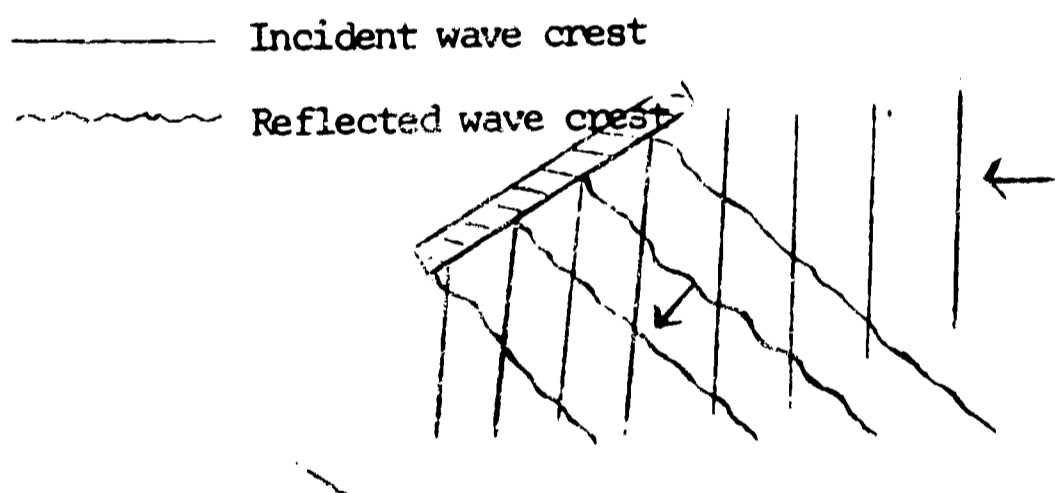

B. Diffraction

Procedure: Observe waves which pass through a small opening in a wall. Describe. Change the width of the opening and see what happens. What happens when the gap is only 1/8" wide?

Observation: Waves that were allowed to pass through an opening in a wall were bent in an arc as they passed through the opening. The larger the opening in the wall, the larger were the diffracted waves. It was noted that the waves spread out as they passed through the opening in the wall and their amplitude decreased the further they got from the opening.

When the opening was about 1/8 of an inch, the curvature of the diffracted waves was acute but they dissipated quickly as they moved from the opening.

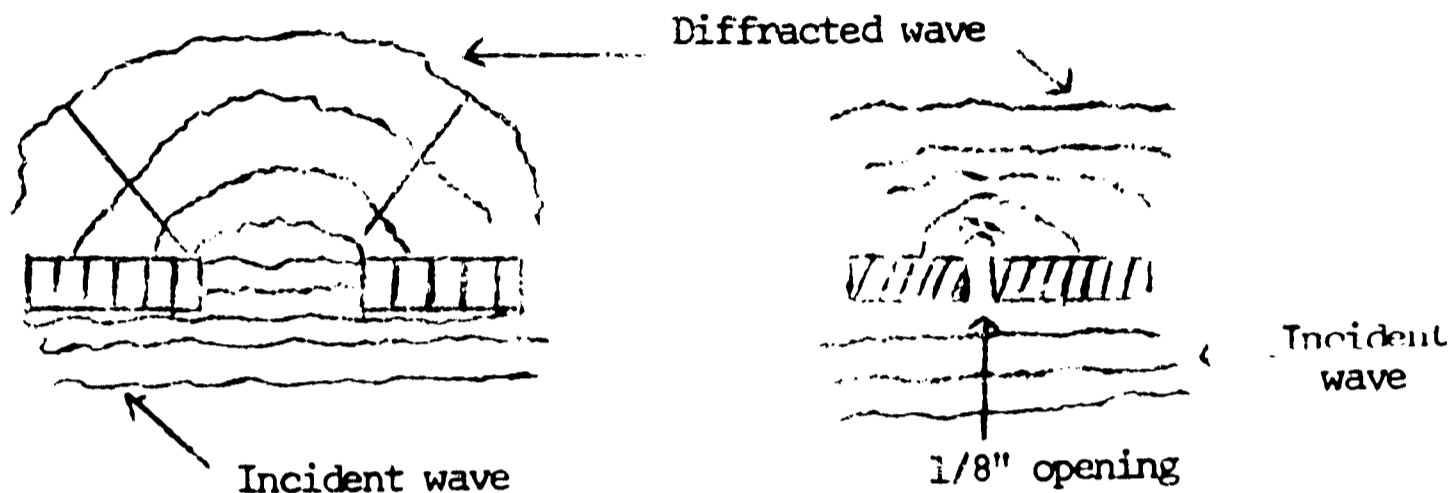

C. Refraction

Procedure: Observe and describe what happens when shallow water waves travel in different depths of water. (Put up a paraffin wall dividing the tank in half. On one side of the wall put down glass plates to make the water shallower.)

Observation: When generated from the same source, waves forced to pass over shallower areas slow down. Their wave length decreases slightly and their amplitude increases slightly.

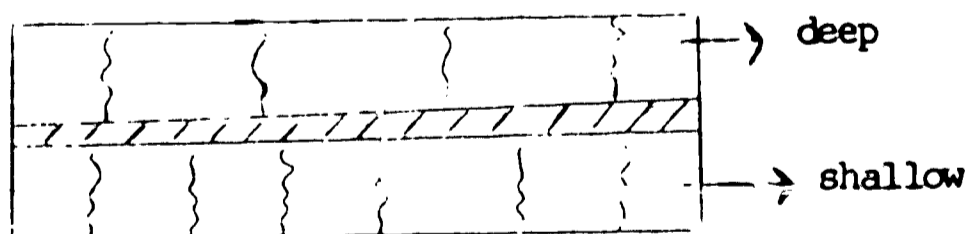

Procedure: Take the wall out and observe the waves traveling in different depths. Describe.

Observation: The waves bent when they passed over the shallow area, with the crest in the shallow area trailing the crest in the deeper area.

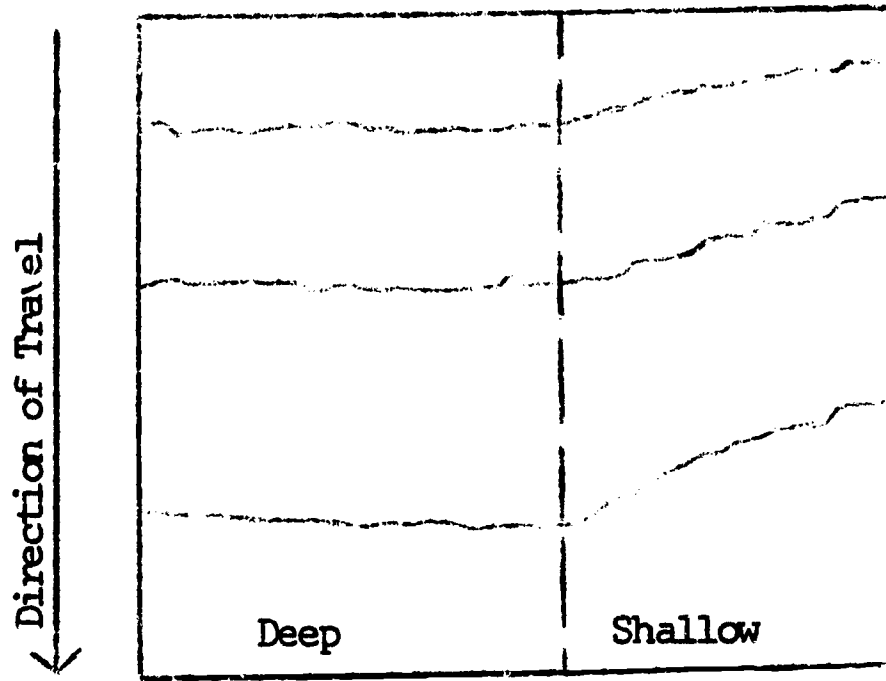

Procedure: Make the water get shallower gradually in one half of the tank. Describe what happens.

Observation: When the water got shallower gradually, the crest of the waves over the shallow portion of the tank curved in toward the shallowest part.

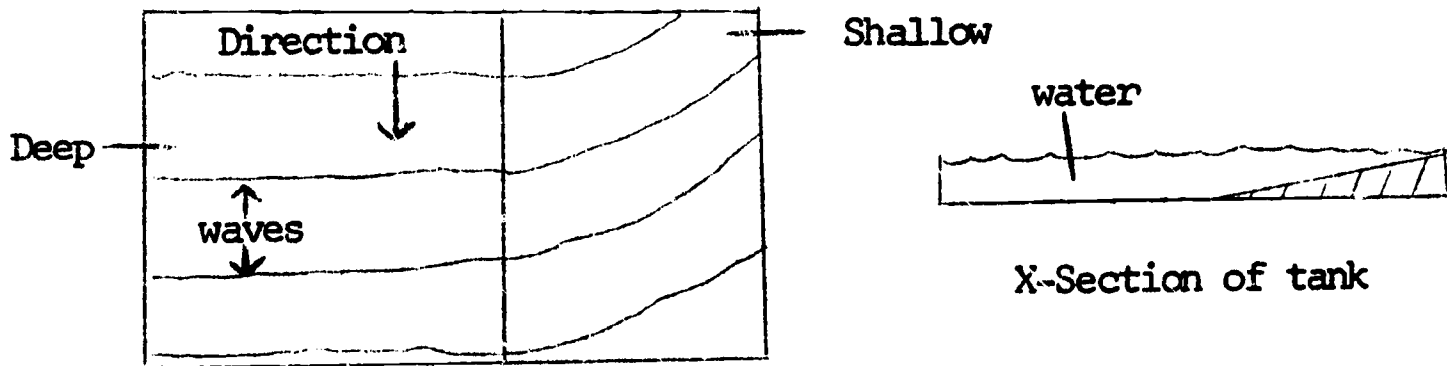

Procedure: Make the water get gradually shallower at an angle to the incident waves. Describe.

Observation: When the water got gradually shallower at an angle, the waves again bent in toward the shallowest part as described in (3) above. The curvature toward the edge of the tank was most noticeable where the upward slope of the bottom was the longest.

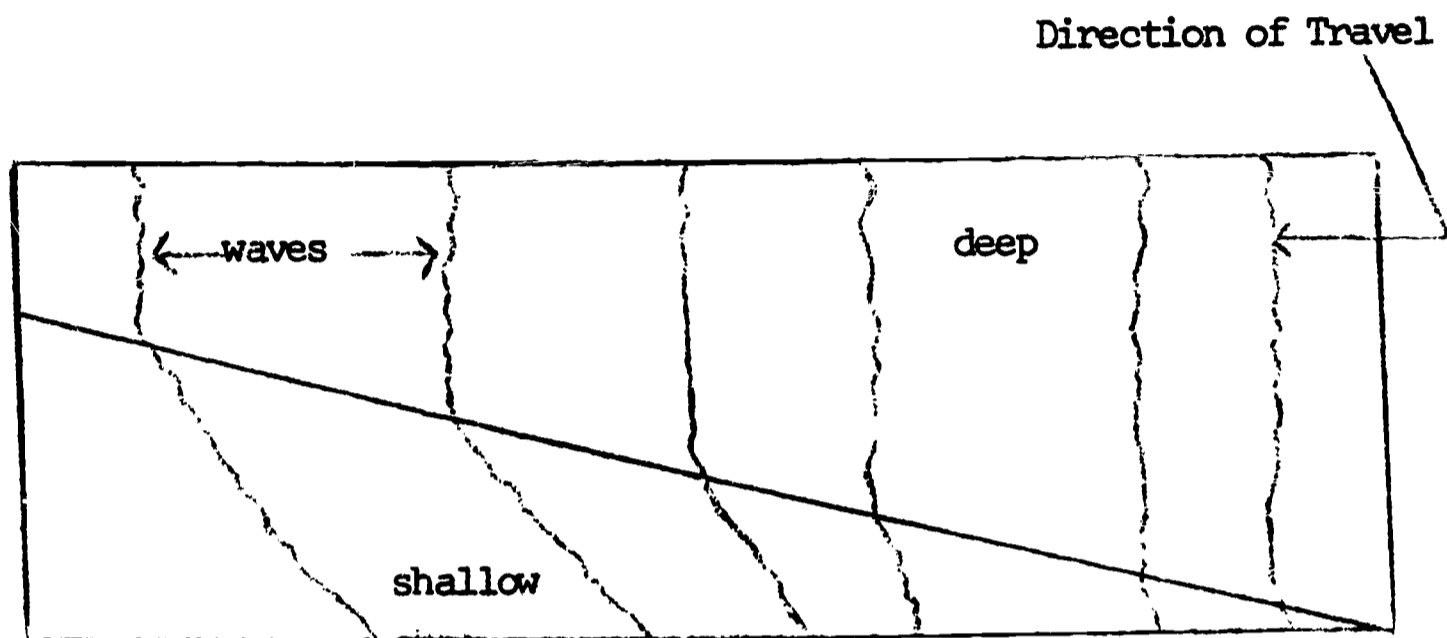

D. Long Wave Channel

Procedure: Fill with 3" of water and create a bore at one end. Observe and describe this bore as it progresses down the channel. Is it highest at the center or the edge? What happens if you make it shallower on one side? (Put a board underneath the plastic.)

Observation: As the wave traveled down the channel it was curved with the center of the crest passing a given reference point prior to the rest of the wave. The amplitude was greatest at the edges of the wave. This was probably because the friction of the walls of the channel slowed the waves, decreased the wavelength slightly, causing a corresponding increase in amplitude (conservation of energy). As the depth of the water was made shallower, the speed of the wave decreased and the amplitude increased.

Procedure: Measure the velocity of waves for different depths of water. Since a wave may be reflected back and forth the length of the channel several times, you can measure the time it takes to travel several lengths of the channel. A fairly accurate velocity can be achieved in this manner.

Plot this data on Log-Log graph paper. You should get a straight line of the form

$$Y = Mx + b$$

$$\text{Log } C = M \text{ Log } h + \text{Log } b$$

or

$$C = bh^M$$

Find M - is it 1/2 as the theory predicts? $C = \sqrt{gh}$ $b = \sqrt{g}$

Observation:

<u>Depth</u>	<u>Time</u>	<u>Passes</u>	<u>Length of Channel</u>
1 cm	18 sec	4	160 cm
2 cm	12 sec	4	160 cm
3 cm	12 sec	5	160 cm
5 cm	12 sec	6	160 cm

Phase velocities

$$\frac{\text{Distance}}{\text{Time}} = \text{Velocity}$$

For h = 1 cm

$$\frac{160 \text{ cm}}{4.5 \text{ sec}} = 35.6 \text{ cm/sec}$$

For h = 2 cm

$$\frac{160 \text{ cm}}{3 \text{ sec}} = 53.3 \text{ cm/sec}$$

For h = 3 cm

$$\frac{160 \text{ cm}}{2.5 \text{ sec}} = 64 \text{ cm/sec}$$

For h = 5 cm

$$\frac{160 \text{ cm}}{2 \text{ sec}} = 80 \text{ cm/sec}$$

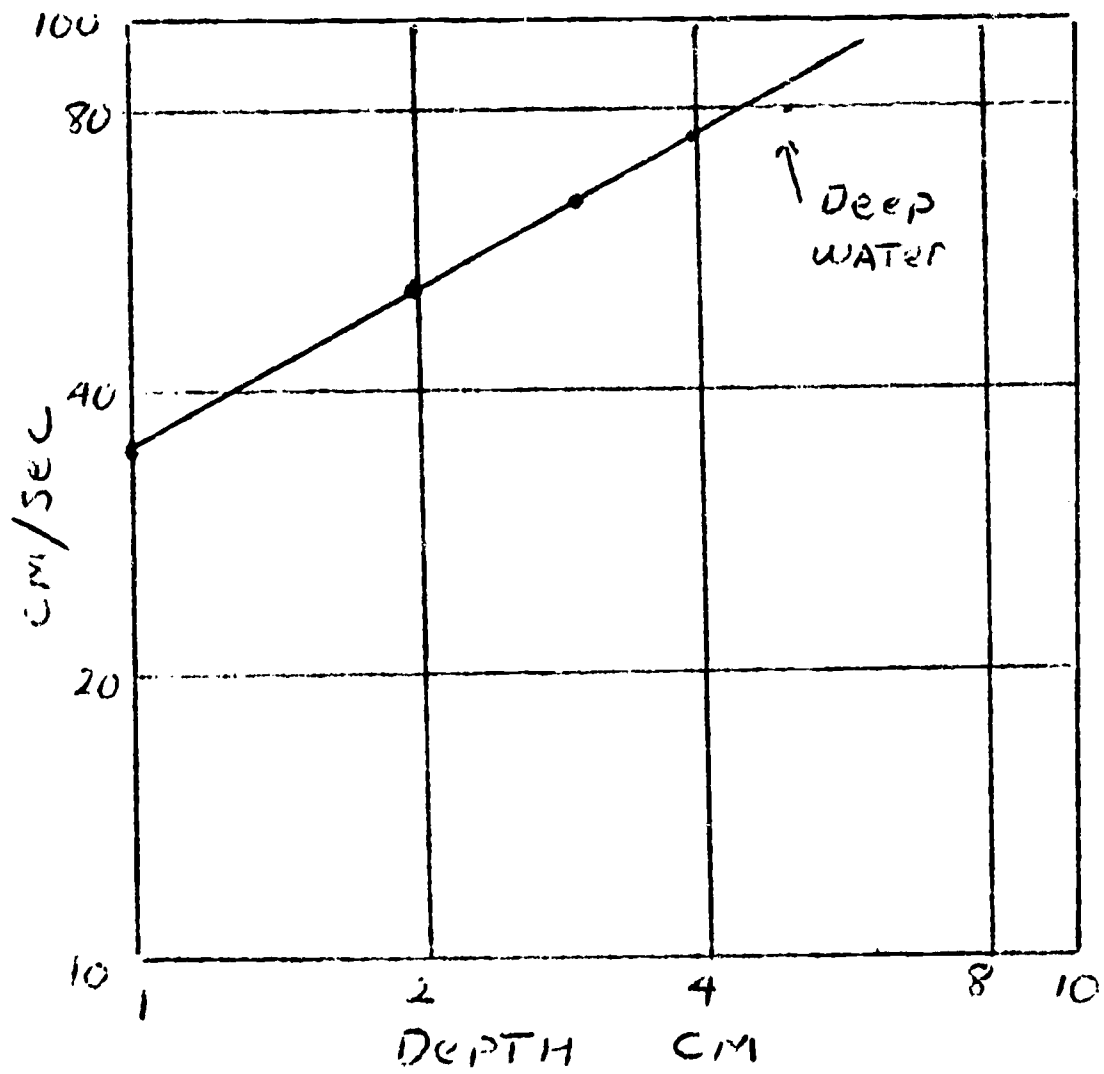

$$\text{Log } C = M \text{Log } g + M \text{Log } h$$

if $C = 65 \text{ cm/sec}$, $h = 3 \text{ cm}$, and

$$M \text{Log } g = 1.552$$

Then

$$1.813 = 1.552 + M \cdot 0.477$$

$$M = 0.555 \approx \frac{1}{2}$$

COMMENTS:

This exercise would be easily adapted for use in the high school, assuming the students have had at least one year of algebra and preferably two. However, since there is no math involved in the ripple tank portion of the exercise, this portion could be used in the junior high and, with some modifications, in the upper grades of the elementary school.

The major problem area of the experiment is with the long wave channel. Construction of a suitable wave channel could be easily performed in the school shop, but storage would be a problem. When funds are available, one side of the channel should be of glass. This would allow a side view of the waves and increase the usefulness of the tank. For instance, the circular motion of water as a wave passes could be demonstrated by placing a plastic float on the surface of the water and observing its motion relative to a grid painted on the glass. This would also allow students to measure the height of a wave if the grid was calibrated and a line representing mean level of the water was drawn. Such a channel could also be filled with sand to demonstrate sand transport of shallow water waves. If desired, sand traps could be set in the sand to determine the volume of sand transported forward and backward with respect to the direction of wave travel. (See diagram below) Also, a glass side would allow students or teachers to take pictures of waves. From a teacher's point of view, this would be most useful. Because construction of enough channels for use by members of a class is impossible, this section of the experiment should be given as a demonstration and pictures would be most useful for future use by students.

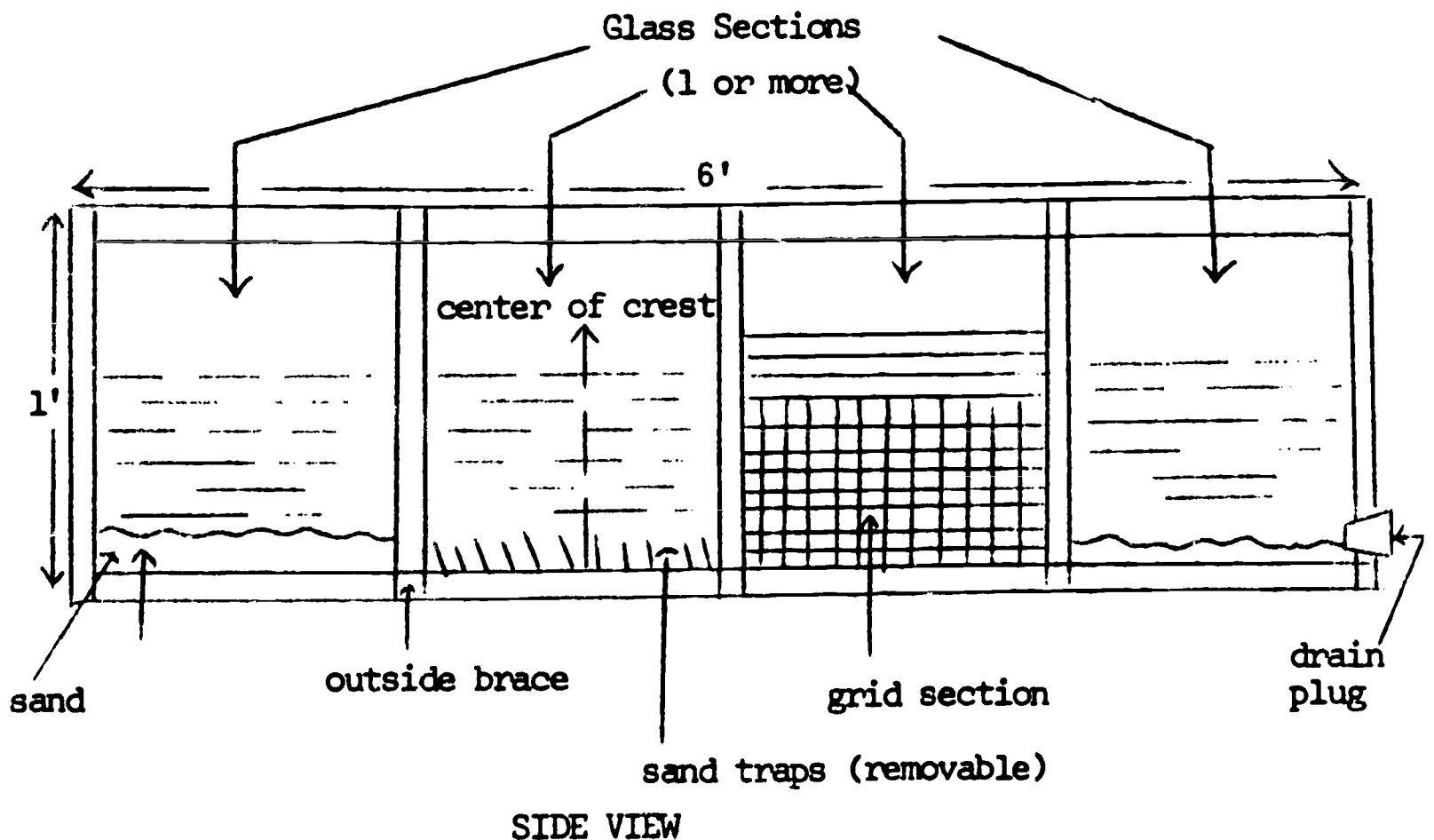

Internal Waves

The waves you see at the beach or when you're out in a boat are not the only waves in the sea! They are surface waves. These surface waves are in reality traveling along an interface between two substances (fluids) of different density; sea water with a density of 1.025 below the interface and air with a density of 0.0013 above. If this density difference were nonexistent there would be no waves at all.

The oceans are about 4000 meters deep on the average and the density of the water is often different at different depths. These differing density layers are caused primarily by different combinations of temperature and salinity. If a disturbance occurs along the interface between two water layers of different density waves are generated. These waves are called internal waves. They have horizontal direction of travel, height and wave length just as surface waves do, but cannot be seen at the surface of the ocean. Internal waves are believed to be important in the mixing of water masses. Internal waves are difficult to observe and must be measured indirectly.

In a recent laboratory exercise, you observed the phenomenon of surface waves. These waves were created and propagated at the boundary between two fluids, air and water. This boundary, the water surface, separated two immiscible fluids of unequal density. The density of water is 1 g/ml and that of air is 0.0013 g/ml. In this laboratory what we will observe are waves that are created and progress at the boundary between two fluids whose densities are not quite so different. We will observe wave propagating at the boundary between two liquids whose densities are different but of the same order of magnitude (the ratio of their densities will be nearly one). It will be seen that these waves do exist and, in many ways, are similar to surface waves (they have the same form and move). These waves are called internal waves because they occur in the liquid and are not apparent at the surface.

Object:

To demonstrate in the laboratory, the phenomenon of internal waves.

Materials:

Fish tank (10-30 gal.); mineral spirits, corn syrup (Karo) food coloring, paddle to generate waves.

Experiment I: Fill an aquarium half-full with water which has been dyed a suitable color (use food coloring). On top of this water pour any other fluid which is nearly immiscible with water. Examples: kerosene, turpentine, gasoline. CAUTION: These fluids are poisonous; their fumes are toxic; they burn very easily. Therefore, handle them with caution.

For our experiment we will use mineral spirits on top of water.

Notice the boundary between the two fluids--it is sharp and clear, similar to the water surface which you observed in dealing with surface waves. Disturb this surface with a plunger and notice the waves which are generated.

How fast do they travel as compared with surface waves?

The best way to observe these waves is by placing a white background at an angle behind the aquarium and lighting it from above. See diagram:

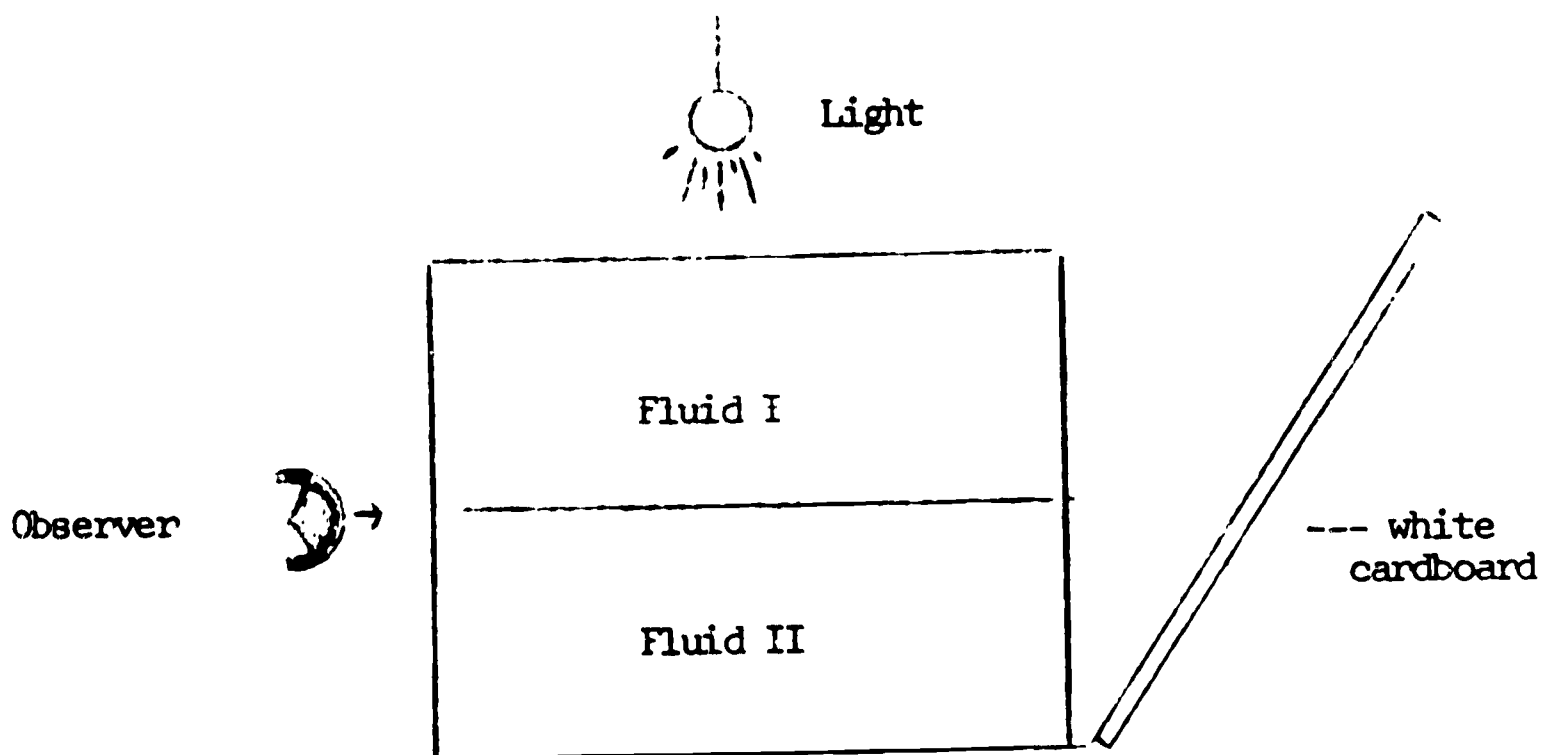

This experiment is exactly the same as the situation where surface waves were observed with the exception that the density of the fluid on top of the water is now 0.82 rather than 0.0013.

This particular situation is unrealistic and usually does not occur in nature because, usually, the two fluids are not immiscible, and a sharp boundary does not exist between them. The most usual case is where light water is found overlying heavy water (warm surface water over cold deep water).

Experiment II: Fill the aquarium half-full with warm fresh water dyed dark red. Then, very carefully, pour cold water into which has been dissolved some corn syrup (a ration of 1 part corn syrup to 20 parts water). If carefully poured into the aquarium down one side, it should go directly to the bottom and not mix appreciably with the water already in the tank. After the tank has been filled in this manner, it will be noticed that the surface water is dark red, the bottom water is clear, and between them is a band of pink water. This pink band is the location of the pycnocline or area of greatest density change.

It is in this pycnocline that we will generate and observe internal waves.

SKETCH:

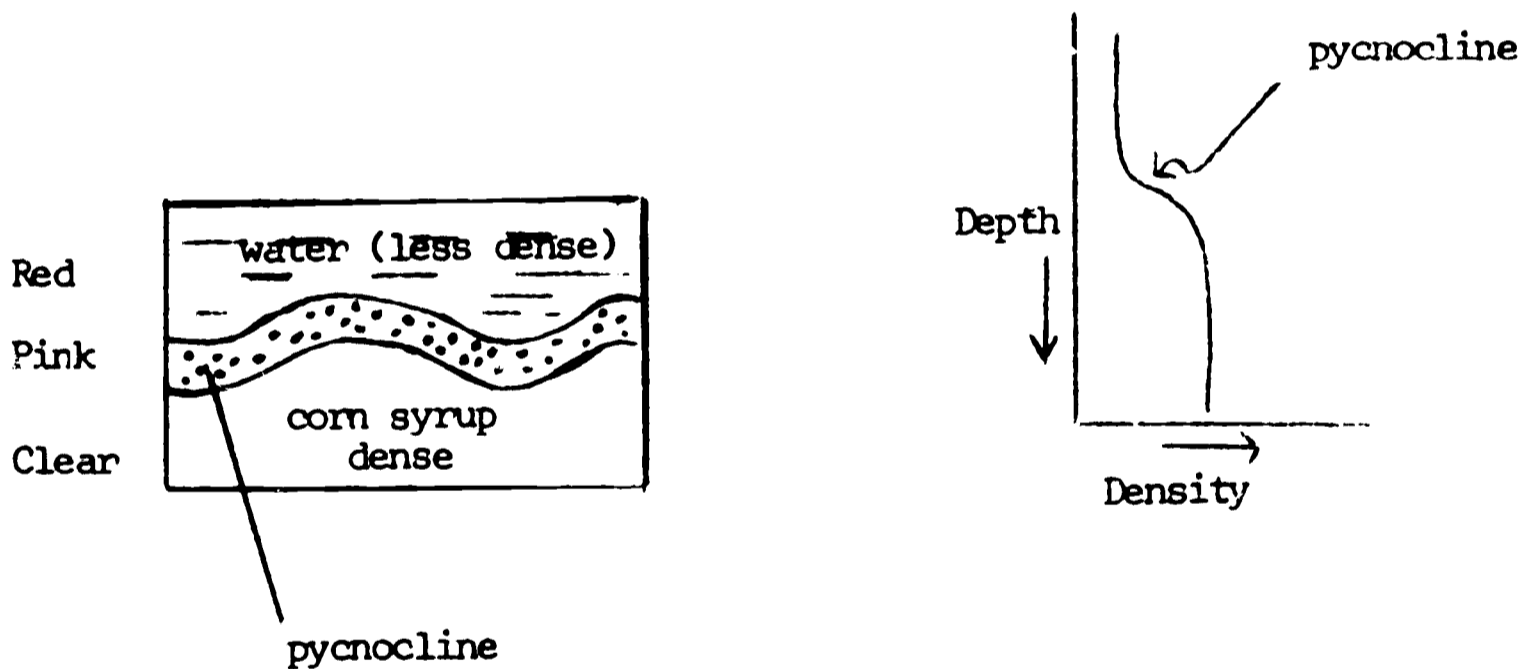

Observations:

After having generated a surface wave and an internal wave simultaneously, notice the difference in shape, height and speed between them. Also compare the duration or persistence of the two.

Questions:

1. Do internal waves travel faster or slower than surface waves?
2. Is the degree of density difference between different water layers as great as the difference between air and water? Would this make a difference in wave characteristics? Would internal waves help in mixing ocean water?
3. How are internal waves detected at sea?

Answers:

1. Slower.
2. Since the velocity of propagation is proportional to the density gradient (change in density), it will be observed that the waves travel fastest in the pink area. Just above and below this band the internal waves travel slower. Because they are traveling at different speeds, shears occur and, therefore, turbulent mixing. The turbulent mixing should be quite apparent.
3. They are detected by taking temperature readings at an oceanic station and by knowing the water temperatures of water masses at various depths. Up and down motion of these water masses can then be determined by vertical changes in temperature. Salinity or oxygen concentrations could also be used as yardsticks.

REPORT ON
MARINE BIOLOGY LABORATORY PROJECTS

Submitted by Members of the
N.S.F. OCEANOGRAPHIC INSTITUTE

During the summer of 1967, a series of projects in marine biology were developed and presented by members of the six-week National Science Foundation Oceanographic Institute held at Florida State University. This report will summarize these projects and attempt to suggest other related ones that might be useful in science classrooms.

Participants in the Institute were all secondary teachers. They worked alone, or in groups, on these projects. Some of the studies, as originally presented, are, perhaps, too advanced for any but the very accelerated twelfth-grade students, while others would be appropriate even for seventh-grade youngsters. With a little ingenuity, the majority of the projects can be adapted to many teaching situations and learning abilities, from the top student with an inquisitive mind who must be challenged, down to the slow learner who needs to be stimulated but not discouraged.

Collecting trips were made every Saturday and Sunday for specimens to be used in these studies. Two night trips were also offered. The Alligator Harbor Marine Laboratory, owned by F.S.U. and located about forty miles south of Tallahassee, served as the base of operations. (See map-- Appendix A.) As indicated, many different adjacent areas were visited. Some collecting was also done on an individual basis in other locations as far afield as Panama City.

Participants were given the opportunity of becoming acquainted with the use of many different types of collecting equipment. (See Appendix B.) A 34-foot boat was used for the trawling and dredging trips, during which plankton nets were also pulled. On several occasions a smaller boat transported participants to Bay Mouth Bar when the tide was low. Here marine grasses grow in abundance, and many kinds of life flourish.

Records were made of each trip on field note forms (see Appendix C) which included lists of specimens collected. Organisms were brought back both alive and preserved. Live specimens were transported in foam buckets, sometimes with the use of aerators. Other specimens were placed in buckets

of formaldehyde solution as they were found, and were thus preserved, to be sorted and keyed out later. Plankton samples were kept in small jars.

It is worth noting that the lack of the sophisticated type of collecting equipment provided by the Institute need not discourage a teacher who wants to give students the experience of collecting trips. As was evident, many fine specimens can be obtained without the use of a boat. Plankton may be caught by pulling nylon hose through the water. Dip nets can be made from a length of nylon hose knotted at the end and sewed to a ring of wire attached to a wooden dowel. Very satisfactory collecting pails (that keep contents from splashing out) can be made from large-size empty bleach bottles. A hole, big enough to insert a hand into, is cut out near the top. (See Appendix D.) Jute seines can be purchased for under five dollars each, and poles to use with them can be cut free from growths of bamboo. (Jute seines must be rinsed very carefully with fresh water after each use, and allowed to dry thoroughly, otherwise they deteriorate rapidly.) Plastic boxes of the type used for closet storage make inexpensive and useful holding tanks for things like colonies of fiddler crabs.

Instructors and students were required to wear sneakers at all times, including on boats and in the water. No teacher should ever plan a field trip without observing this precaution.

The projects, when completed were found to fall into three major categories, plus a miscellaneous one. Several might have been placed in more than one category, but will be detailed in only one. They are as follows:

1. Behavioral studies
2. Ecological studies
3. Collections
4. Miscellaneous (including laboratory and physiological studies)

Participants were required to state their objectives, materials used, methods, and give general background information. Then, they were to present their conclusions and cite references.

These projects varied considerably as to depth of study, length, success of objectives (sometimes the necessary specimens could not be found, sometimes the specimens died before observations were concluded). Other projects were completely successful in terms of doing what the writer set out to do. But every participant seemed to feel that even when proposed goals had not been reached, much had been learned.

In this respect, all the projects were successful.

BEHAVIORAL STUDIES

1. Behavior of Hermit Crabs Without Shells

The writers of this paper set out to find how hermits could best be removed from their shell homes without injury, and, then, how the naked Pagurus would behave under various conditions. (They found that the only successful way to get the animal out was to drill a hole in the shell and prod him out.) They carried out numerous experiments with the naked animal, including observing him when he was touched, and watching him try to find a new home.

This sort of study, just as it stands, would be very good for high school students. There are ample reference works on the market written at high school level which would help give students background for observations of this type. No elaborate equipment is necessary to set up this type of study.

2. A Study of the Fiddler Crab - Uca Pugilator

The authors of this paper secured a colony of fiddler crabs and tried housing them in various types of sand and gravel (they did not like the gravel). They watched them digging in, observed their feeding habits, and also made notes on their actions in the field.

Many useful experiments might be performed using Uca. One that is not new, but that would be of great interest to high school students, would be observations of the circadian rhythms of these crabs. It would try to tie in color changes both with time of day and night, and the tides. This might be done by using a control group and other colonies that would be exposed to lights of various colors or kept in total darkness. Eyestalks might also be removed. Keeping them at different temperatures to see if this affects color changes might also be interesting.

Any teacher can keep these animals in a classroom for long periods of time. They need some of the sand or mud in which they were found (to burrow in) and salt water (to keep their gills moist). They live contentedly when fed dried fish food (medium or fine size, not flake).

3. Locomotive Behavior of Echinodermata

Because these animals, for the most part, move with extreme slowness, the writer tried additional bits of experimentation, such as turning them upside down and observing their efforts to right themselves. An interesting finding was that daytime observations were found to be negative--nighttime observations were far more rewarding.

Again, this would make an interesting project for high school students as these animals are quite easily obtained and do not require an elaborate set-up to maintain.

ECOLOGICAL STUDIES

1. Oyster Reefs as Ecological Communities - (Biocoenosis)

This paper makes a comprehensive and detailed study of oyster reefs in local estuaries.

A simpler study of this type would be readily adaptable to high school students.

Other variations might include the following, as per Mr. Dunstan's suggestion. Lower a concrete block into the water and have students observe the succession of marine life that will grow upon it. A count every two weeks for several months would be needed.

Or, a student might select a portion of a piling, and record the life to be found there over a given period of time.

Another useful project might be to make a larva mat as Dr. Warsh did, by tying padding of the type used to pack instruments, around a brick (use wire) and hanging it into the water for several weeks.

2. Distribution of Marine Protozoans Over a Two-Mile Area of Ochlocknee Bay

Samples were taken from three-foot depths at different points, proceeding against an outgoing tide which meant different salinities. These salinities were then recorded after testing. The writer mentioned that he would like to

have included results gathered during an incoming tide. Not a great variation in the number of animals from different spots was found.

The only difficulty students might find in such an experiment is in doing the math required for finding out salinities, but by high school, most should be able to handle it.

Mr. Dunstan made a suggestion that would be useful for an experiment dealing with plankton. He suggested adding one teaspoon of a commercial 5-10-5 fertilizer to a gallon jar of unfiltered sea-water. Divide it into two containers, keeping one in light and covering up the other so it is in darkness. Then, compare relative densities of the plankton populations by holding some of the water from each container up to the light in a test tube.

COLLECTIONS

A number of different collections were made, all preserved, although one of them started out as a live tank collection. These projects will only be presented briefly here, although several of them involved an extensive amount of work in obtaining specimens and in keying them out. Several participants who did not choose to make collections as their project, nevertheless, preserved and kept many specimens in order to start type collections for their schools.

Collections are valuable for high school students to make. They learn while they are finding the organisms. The learning continues when they identify them.

1. Decapod Collection Representing Sub-Orders Anomura and Brachyura

Specimens for this project were collected, keyed and, then, preserved. (The instructor suggested it might be wise to key after preserving!)

2. Anomuran and Brachyuran Crabs

This writer did not reach his objective, which was to secure a representative specimen of each Anomuran and Brachyuran Crab to be found in the vicinity of Alligator Harbor. But he obviously increased his knowledge of crabs greatly. This

points up one of the things that a teacher should help students learn--that "success" can be achieved in many different ways.

A simple experiment that might be made using live crabs of these and other groups is to see how long they can live without water--whether desiccation of the gills takes place more rapidly or is more harmful in some species than in others.

3. Echinodermata

A representative specimen of each species of echinoderm that was found on the field trips was discussed in this paper.

4. Collection and Identification of Macroscopic Marine Algae in Selected Areas

Specimens were arranged on paper, placed in a press, and, then, dried. Semi-dry specimens were also placed in plastic bags and put on ice. Many were in good condition after ten days or more.

A collection mounted in this manner is very beautiful as well as instructive. This would be a good project for high school students. A study might be made as to which ones were found with holdfasts, which ones were floating, and in what depth of water.

5. Mollusca Collection from Areas of Apalachee Bay and Alligator Harbor

Live specimens were collected in order to make a more thorough study than would be possible from empty shells. Squid were preserved in formaldehyde. Hard-shelled specimens were boiled and the remains removed.

It is worth noting that collectors of mollusk shells use several approaches in preparing and keeping shells. Some polish the shells with baby oil to make them glossy. Others leave them in the natural state where any growths on the shell may be observed. Then, there is a third group who clean and polish one small area so that the design on the shell may be seen, but the natural effect not destroyed. The operculi of gastropods should be saved and kept with the shell.

6. Collection of Marine Specimens Which May Be of Interest to High School Students

The authors of this paper live and teach forty miles from salt water. They started a miscellaneous collection of marine animals to take back to their school.

7. Establishment and Maintenance of a Community Marine Aquarium

Primary considerations in this project were to observe factors causing pollution, and to find out by practical experience factors governing aeration, salinity, temperature, and feeding, in order to ascertain the most optimum conditions for keeping the majority of animals.

Conclusions reached were that crabs were the most successful organisms in a community tank. Fish tended to die. The most successful food was dried tropical fish food.

After the animals were observed and keyed out, they were preserved and are to be used in a school collection.

This certainly is a project in which all students of marine biology should be involved at one time or another. Studies of group living, of predators and victims, of discovering which animals pollute tanks and which ones help keep them clean, organisms that burrow, those that remain on the bottom, and those that swim around, all will teach students a tremendous amount.

MISCELLANEOUS

1. Salinity Tolerance of Fundulus similis

The killifish is a euryhaline marine organism. The lowest salinity range in which the authors were able to keep their fish alive was 2.6 ‰ to 34.6 ‰ (p pt).

Studies involving salinity tolerances (as well as temperature tolerances) might be made of many animals. The adaptability of oysters to different degrees of salinity as contrasted to the starfishes' need for a high salt content might make an interesting study for a student, in order to

find out in what kind of water the one animal would normally prey on the other.

2. Partial Survey of Significant Characteristics (Anatomical, Functional and Ecological) Pertinent to the Eyes, Nostrils, Barbels, Fins and Projections, Otoliths, Weberian Apparatus and the Lateral Line in the Classes Osteichthys and Chondrichthys

The writer of this paper went into considerable detail on the characteristics listed above of a number of different fishes. When such detailing comes from personal observation (with a background of research) it is of tremendous value to students of any age.

A study that would be of interest to students would be to take a fish (say, a small grouper or a flounder) or another marine animal that is capable of color changes (as distinguished from biologic clock changes) and see how the animal adapts himself to different types of floors or background in tanks. A flounder might be placed in tanks with different colored stones, checkerboard pattern and other designs on the bottom. A catfish might be put first in a tank with white back and sides, and, then, in one with black back and sides. Squid might also be used (although not a fish).

3. Cocci and Bacilli in Sea Water

This was a study made by obtaining sea water from near a shell. Stained slides were produced, which were found to contain three types of cocci, but no bacilli.

The preparation and staining of slides is of immense value to high school students. Any number of projects dealing with microscopic organisms is appropriate for this age student.

4. Recent Littoral Foraminifera from Alligator Harbor

Samples were taken from several locations at Alligator Harbor. The only significant amounts of Foraminifera were found in a location where bottom sediments were mixed and turtle grass grew in abundance. Some attempt (moderately successful) was made to cultivate living Foraminifera in the laboratory.

This type of study would be of value to high school students especially if a considerable number of areas were sampled. This would not be difficult in a coastal city.

A number of other projects, of types that were not chosen during this Institute, present themselves as possibilities. The common intertidal barnacle Balanus offers tremendous possibilities, both for study at a site, and in the laboratory. At the site it is interesting to make a study of the growth of barnacles (do the ones who live singly grow any larger than the ones who live in colonies?). In the laboratory it is interesting to find out how long the animals can stay alive away from water (normally they close up between tides). Sometimes, even when they appear to be dead, they will revive when moistened again. These animals are also very good for studies of salinity tolerances and temperature changes (application of Van't Hoff's law).

Another experiment which would be of interest to high school students would be the one that Dr. Oppenheimer suggested, which had to do with groups of microorganisms reducing organic substances to inorganic. He suggested accomplishing this by taking a dead fish and putting it in a glass jar, buried in sediment, but so that the fish is near the edge and can be observed. The sediment should be natural mud. Throw in a little water, do not seal the container, and, then, watch what happens. (A black precipitate is produced).

Ideally, high school students studying marine biology should each have their own tank in a lab situation of a gang-type hook-up. This enables them to make constant evaluations of what is going on in the water, and stimulates them to go out and find new organisms to put in the tanks. But a teacher who does not have these facilities need not feel that much of value has to be eliminated, as long as some tanks are available.

When students are able to choose their own projects to work on, instead of being arbitrarily assigned ones that appeal to the teacher, the chances of great interest being generated are much enhanced. Sometimes studies may be done as class projects, with the student who wishes to go into more depth being permitted, indeed, encouraged, to make a lengthier study.

Even with minimum facilities, as long as our waters continue to supply us with fascinating organisms, much useful study with live specimens is possible. It is important, as part of the total ecological picture, to make students aware

-85-

that their children may not have the same privilege of going to the shore and collecting plants and animals, unless something is done to prevent the destruction of bays and marine grasses, and the pollution of our water, which is taking place in so many areas.

MAP SHOWING COLLECTING TRIP AREAS

- Key:
- Trawl and/or Plankton nets TTTT
 - Dredge oooo
 - Seine <<<<
 - Hand collecting ΔΔΔ
 - push nets, ΔΔΔ
 - screens, etc. >>>>

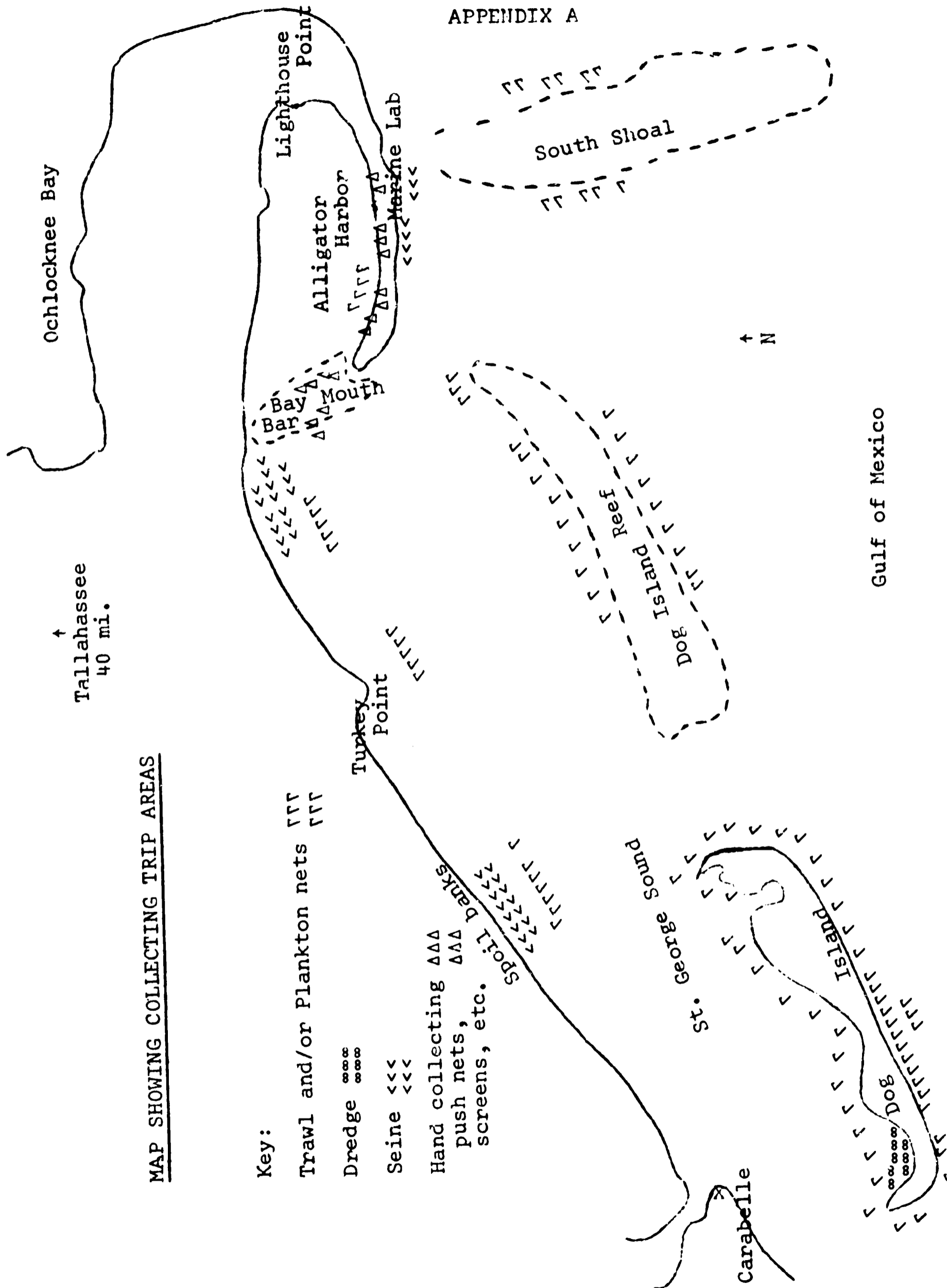

APPENDIX A

Gulf of Mexico

APPENDIX B

Equipment Used on Collecting Trips

- Boat trips:
1. Otter trawl
 2. Dredge
 3. Long-handled dip net
 4. Plankton nets (#0 and #20)

Beach trips (hand collecting was used here to a large extent):

1. Seines, 15-foot and 100-foot
(although 25'-50' seines are generally preferred)
2. Shovels and screens
3. Dip nets
4. Crab collecting device

Trips to flats at low tide (hand collecting was used here also):

1. Push net
2. Shovels and screens

APPENDIX C

FIELD NOTES

DATE	TIME	COLLECTION #
STATE	COUNTY	
LOCATION		
WEATHER		
WATER TEMP.	DEPTH	SALINITY
TIDE	DISTANCE FROM SHORE	
TURBIDITY	BOTTOM	
VEGETATION		
ADDITIONAL NOTES		

COLLECTOR	METHOD OF COLLECTION	
SPECIES COLLECTED	NUMBER	SIZE (mm)

- 1.
- 2.
- 3.
- 4.
- 5.
- 6.
- 7.
- 8.
- 9.
- 10.

APPENDIX D

HOMEMADE
DIP NET

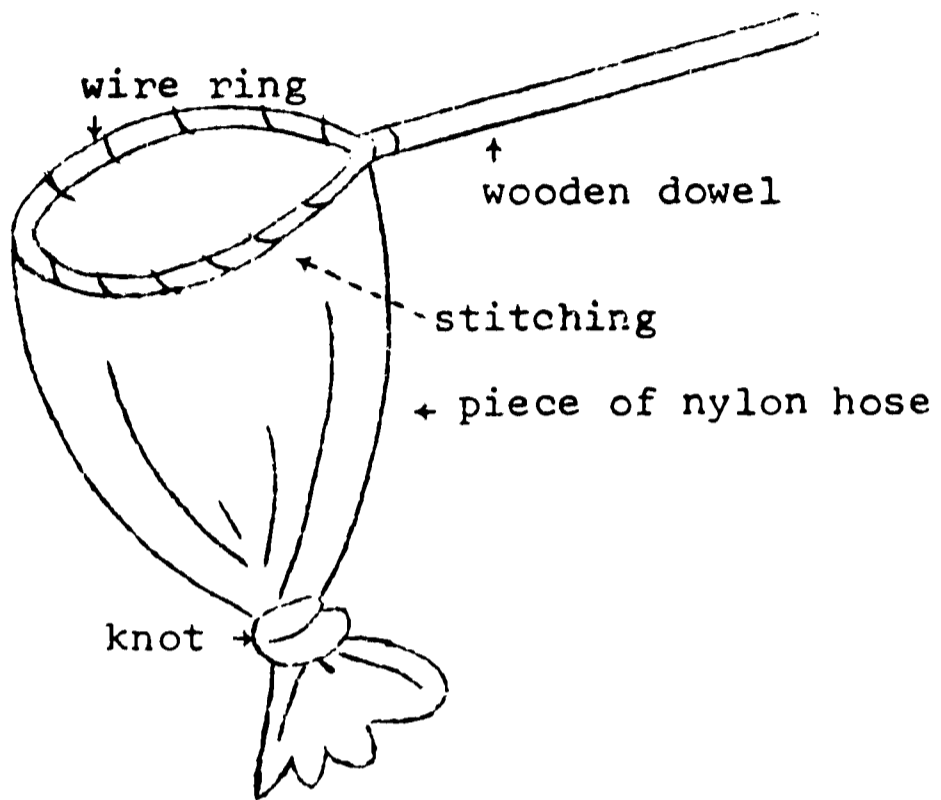

HOMEMADE
COLLECTING PAIL

